



Spare Parts List
Ersatzteilliste
Liste de pièces détachées
Lista de piezas de repuesto

2012-07



PLM5113

995700648 (D, GB, F, E)

PLM4120, PLM4620,
PLM4621, PLM4622,
PLM4623, PLM5113

10

PLM5113
PLM5113
PLM5113
PLM5113

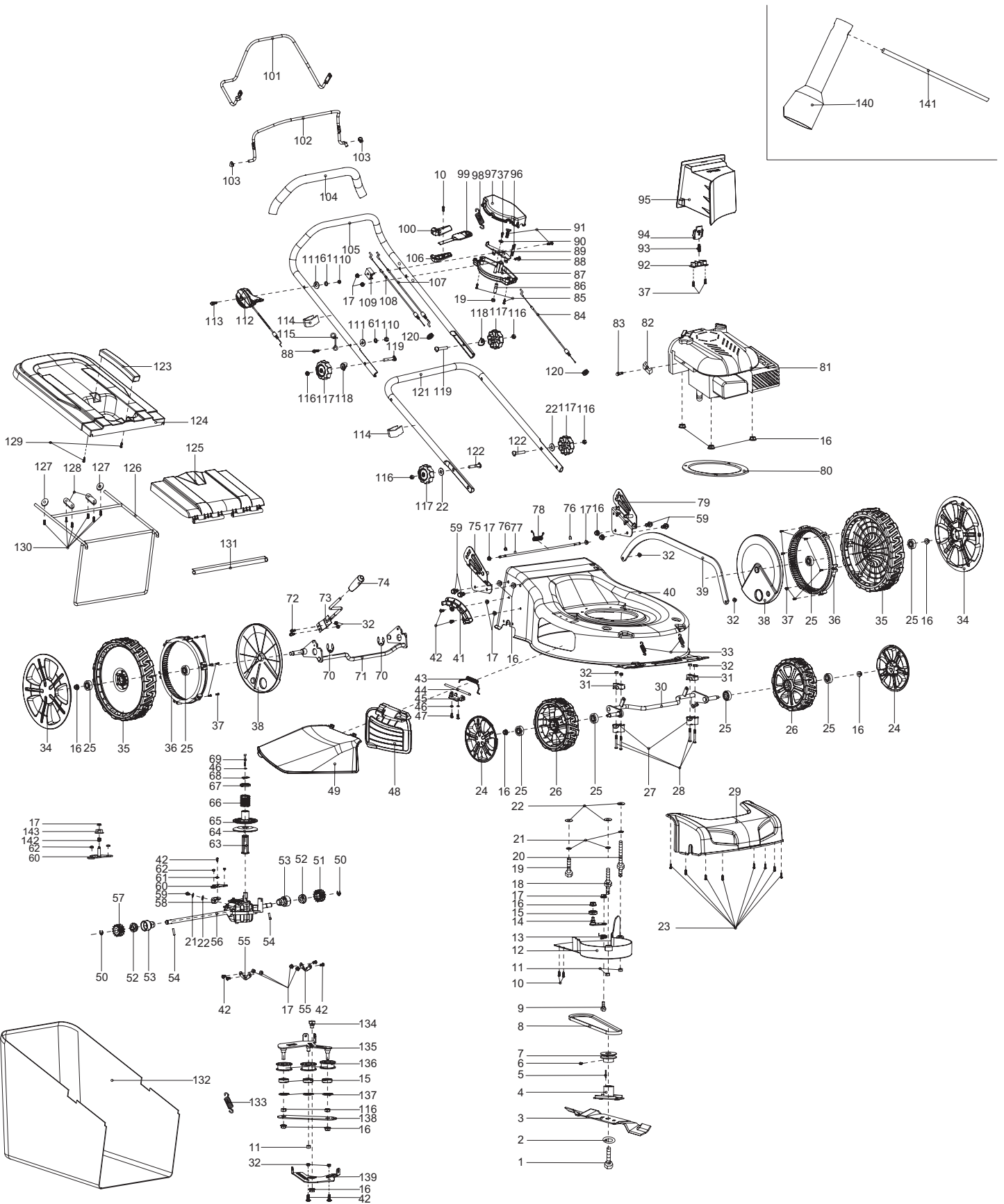

PLM4120, PLM4620,
PLM4621, PLM4622,
PLM4623, PLM5113

10

PLM5113
PLM5113
PLM5113
PLM5113



Seite / Page	Pos.	PLM5113	Teil-Nr. Part No. No. de pièce No. de pieza	Hinweise Notes Renseign. Nota	Bezeichnung	Spezifikation Specification	Description	Désignation	Denominación
10	1	1	671 006 062		MESSERSCHRAUBE		BLADE TIGHTEN SCREW	VIS DE LAME	TORNILLO DE LA CUCHILLA
10	2	1	671 010 730		SCHEIBE	Φ44.5/10.2x2.5	LID SHAPE WASHER	RONDELLE	ARANDELA
10	3	1	671 001 554		MESSER	510mm	BLADE	LAME	CUCHILLA ESTÁNDAR
10	4	1	671 015 252		MESSERHALTER		BLADE SUPPORT	MOYEU	SOPORTE DE LA CUCHILLA
10	5	1	671 090 002		PASSFEDER	4.8*4.7*46.5	FLAT KEY	CLAVETTE	CHAVETA
10	6	1	671 003 005		6KT-SCHRAUBE	M6x8	HEXAGON HEAD BOLT	VIS À SIX PANS	TORNILLO HEXAGONAL
10	7	1	671 004 013		RIEMENSCHLEIBE		PULLEY	POULIE À GORGE POUR COURROIE	DISCO DE LA CORREA
10	8	1	671 002 032		KEILRIEMEN	857 mm	V-BELT	COURROIE TRAPÉZOÏDALE	CORREA CUNEIFORME
10	9	1	671 006 066		SCHRAUBE		SCREW	VIS	TORNILLO
10	10	3	671 001 047		SCHRAUBE SELBSTSCHNEIDEN D	4.2x15	SELF-TAPPING SCREW	VIS DE FORAGE	TORNILLO PERFORADOR
10	11	3	671 005 008		6KT-MUTTER	M8	HEXAGONAL LOCKING NUT	ECROU HEXAGONAL	TUERCA HEXAGONAL
10	12	1	671 522 001		RIEMENABDECKUN G		BELT COVER	COUVERCLE DE COURROIE	CUBIERTA DE CORREA
10	13	1	671 011 136		FEDER		SPRING	RESSORT	MUELLE
10	14	1	671 001 539		FIXIERBLECH		FIXED PLATE	FIXATION	FIJACIÓN
10	15	4	671 004 015		KUGELLAGER	6001RS	BALL BEARING	ROULEMENT À BILLES	RODAMIENTO DE BOLAS
10	16	15	671 005 028		6KT-MUTTER	M8	HEXAGONAL LOCKING NUT	ECROU HEXAGONAL	TUERCA HEXAGONAL
10	17	12	671 005 024		6KT-MUTTER	M6	HEXAGONAL LOCKING NUT	ECROU HEXAGONAL	TUERCA HEXAGONAL
10	18	1	671 003 044		SPEZIALSCHRAUBE	M8x17x35	SPECIAL SCREW	VIS SPÉCIALE	TORNILLO ESPECIAL
10	19	1	671 006 025		6KT-SCHRAUBE	M8x35	HEXAGON BOLT	VIS À SIX PANS	TORNILLO HEXAGONAL
10	20	1	671 003 024		SPEZIALSCHRAUBE	M8x60x17	SPECIAL SCREW	VIS SPÉCIALE	TORNILLO ESPECIAL
10	21	4	671 008 002		FEDERING	φ8,65	SPRING RING	RONDELLE À RESSORT	ANILLO ELÁSTICO
10	22	6	671 007 007		SCHEIBE	φ8	WASHER	RONDELLE	ARANDELA
10	23	8	671 001 062		SCHRAUBE SELBSTSCHNEIDEN D	4,2x10	SELF-TAPPING SCREW	VIS DE FORAGE	TORNILLO PERFORADOR
10	24	2	671 001 177		RADKAPPE	8"	WHEEL COVER	CHAPEAU DE MOYEU	CAPERUZA DE RUEDA
10	25	8	671 004 012		KUGELLAGER	6201Z	BALL BEARING	ROULEMENT À BILLES	RODAMIENTO DE BOLAS
10	26	2	671 020 160		RAD	8"	WHEEL ASSY.	ROUE	RUEDA
10	27	2	671 418 001		LAGERSCHALE		FIXED BRACKET	COQUILLE DE COUSSINET	MITAD DE RODAMIENTO
10	28	4	671 002 028		SCHRAUBE	M6x45	TRIGGER BOLT	VIS	TORNILLO
10	29	1	671 513 001		FRONTTEIL		GRILL	PANNEAU	FRONTAL CUBIERTA
10	30	1	671 001 573		VORDERACHSE		FRONT WHEEL AXLE	ESSIEU AVANT	EJE DELANTERO
10	31	2	671 445 001		LAGERSCHALE		PRESSING PLATE OF BRACKET	COQUILLE DE COUSSINET	MITAD DE RODAMIENTO
10	32	10	671 005 005		6KT-MUTTER	M6	LOCKING NUT	ECROU	TUERCA
10	33	2	671 011 142		ZUGFEDER		EXTENSION SPRING OF FRONT WHEEL AXLE	RESSORT	RESORTE
10	34	2	671 001 322		RADKAPPE		WHEEL COVER	CHAPEAU DE MOYEU	CAPERUZA DE RUEDA
10	35	2	671 002 021		RAD KPL.		WHEEL ASSY.	ROUE CPL.	RUEDA CPL.

PLM4120, PLM4620,
PLM4621, PLM4622,
PLM4623, PLM5113

10

PLM5113
PLM5113
PLM5113
PLM5113

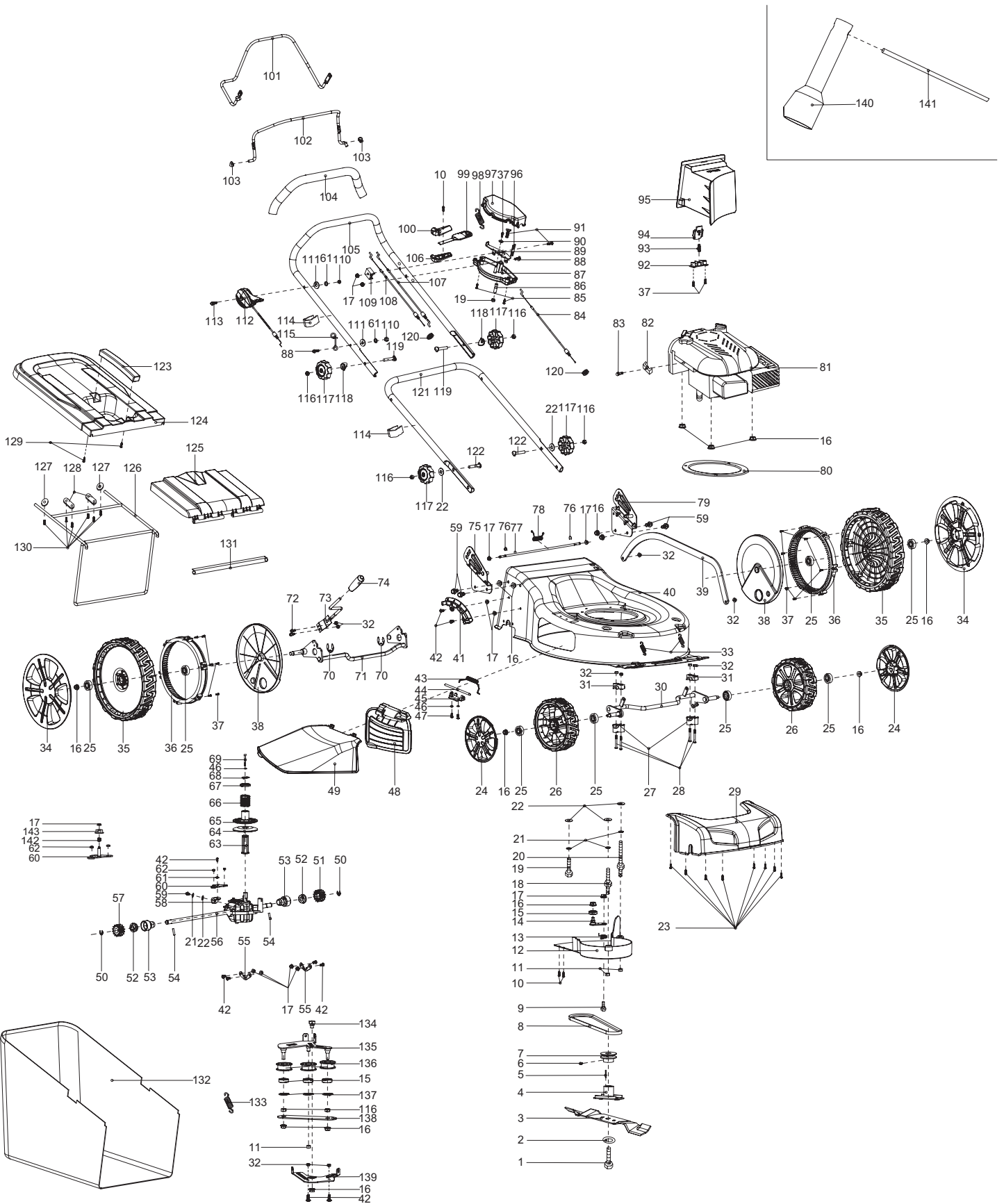

PLM4120, PLM4620,
PLM4621, PLM4622,
PLM4623, PLM5113

10

PLM5113
PLM5113
PLM5113
PLM5113



Seite / Page	Pos.	PLM5113	Teil-Nr. Part No. No. de pièce No. de pieza	Hinweise Notes Renseign. Nota	Bezeichnung	Spezifikation Specification	Description	Désignation	Denominación
10	36	2	671 520 001		ZAHNRAD		GEAR WHEEL	ROUE DENTEE	PIÑÓN
10	37	15	671 001 005		SCHRAUBE SELBSTSCHNEIDEN D	4x16	SELF-TAPPING SCREW	VIS DE FORAGE	TORNILLO PERFORADOR
10	38	2	671 518 001		RAD-INNENABDECK UNG		INNER WHEEL COVER	CHAPEAU DE MOYEU	CAPERUZA DE RUEDA
10	39	1	671 001 575		VERBINDUNGSSTA NGE		LINK ROD	BARRE DE RACCORDEMENT	BARRA DE CONEXIÓN
10	40	1	671 001 326		HAUBE	Makita Green	DECK	CAPOT	CAPOTA
10	41	1	671 010 280		DREHPUNKT FÜR HÖHENVERSTELLU NG		HEIGHT ADJUSTMENT PLATE	POINT DE ROTATION POUR LE RÉGLAGE EN HAUTEUR	PUNTO DE GIRO PARA REGLAJE DE ALTURA
10	42	9	671 002 019		SCHRAUBE	M6x12	TRIGGER BOLT	VIS	TORNILLO
10	43	1	671 011 130		FEDER		SPRING	RESSORT	RESORTE
10	44	1	671 001 019		ACHSE		AXLE	AXE	EJE
10	45	1	671 001 571		FIXIERBLECH		FIXED PLATE	FIXATION	FIJACIÓN
10	46	3	671 008 004		FEDERSCHEIBE	φ5	SPRING WASHER	RONDELLE A RESSORT	ARANDELA ELASTICO
10	47	2	671 201 501		SCHRAUBE		TRIGGER BOLT	VIS	TORNILLO
10	48	1	671 514 001		MULCHABDECKUN G		SIDE DISCHARGE COVER	COUVERCLE	CUBIERTA
10	49	1	671 516 001		SCHUTZHAUBE SEITENAUSWURF		PROTECTION COVER	CAPOT DE PROTECTION	CUBIERTA PROTECTORA
10	50	2	671 090 020		SICHERUNGSSCHEI BE		SAFETY WASHER	RONDELLE SÉCURITÉ	ARANDELA SEGURIDAD
10	51	1	671 003 001		ZAHNRAD, LINKS		GEAR WHEEL, LEFT	ROUE DENTEE, GAUCHE	PIÑÓN, IZQ.
10	52	2	671 004 017		LAGER		BEARING	ROULEMENT	RODAMIENTO
10	53	2	671 002 024		LAGERGEHÄUSE		BEARING HOUSING	CARTER	CÁRTER
10	54	2	671 090 001		ZYLINDERSTIFT	φ5x21.5	CYLINDRICAL PIN	GOUPILLE CYLINDRIQUE	PASADOR CILINDRICO
10	55	2	671 001 244		FIXIERUNG		RING OF AXLE FIXING	FIXATION	FIJACIÓN
10	56	1	671 501 031		ANTRIEB		GEAR BOX	GROUPE TRACTION	UNIDAD DE TRACCIÓN
10	57	1	671 003 002		ZAHNRAD, RECHTS		RIGHT GEAR	ROUE DENTEE, DROITE	PIÑÓN, DERECHA
10	58	1	671 001 521		BEFESTIGUNGSBLE CH	2	FIXING PLATE	TÔLE DE FIXATION	CHAPA DE FIJACIÓN
10	59	5	671 006 064		6KT-SCHRAUBE	M8x6	HEXAGON HEAD BOLT	VIS À SIX PANS	TORNILLO HEXAGONAL
10	60	1	671 001 717		BEFESTIGUNGSBLE CH		FIXED PLATE OF GEAR BOX	TÔLE DE FIXATION	CHAPA DE FIJACIÓN
10	61	3	671 008 003		FEDERSCHEIBE	φ6,65	SPRING WASHER	RONDELLE A RESSORT	ARANDELA ELASTICO
10	62	2	671 005 011		6KT-MUTTER	M5	HEXAGONAL LOCKING NUT	ECROU HEXAGONAL	TUERCA HEXAGONAL
10	63	1	671 001 082		ANTRIEBSACHSE KPL., UNTEN		LOWER DRIVEN AXLE ASS'Y	AXE D'ENTRAÎNEMENT CPL., INF.	EJE DE ACCIONAMIENTO CPL., INF.
10	64	1	671 001 082		ANTRIEBSACHSE KPL., UNTEN		LOWER DRIVEN AXLE ASS'Y	AXE D'ENTRAÎNEMENT CPL., INF.	EJE DE ACCIONAMIENTO CPL., INF.
10	65	1	671 010 540		RIEMENSCHLEIBE, OBEN		PULLEY, UPPER	POULIE À GORGE POUR COURROIE, SUP.	DISCO DE LA CORREA, SUP.
10	66	1	671 011 122		FEDER		SPRING	RESSORT	MUELLE
10	67	1	671 001 457		DRUCKSCHEIBE		CLAMP WASHER	DISQUE DE PRESSION	DISCO DE PRESION
10	68	1	671 009 020		RING	φ19	RING	ANNEAU	ANILLO
10	69	1	671 006 123		SCHRAUBE	M5x55	BOLT	VIS	TORNILLO
10	70	2	671 009 003		SICHERUNGSSCHEI BE	φ19x1.5	SAFETY WASHER	RONDELLE SÉCURITÉ	ARANDELA SEGURIDAD

PLM4120, PLM4620,
PLM4621, PLM4622,
PLM4623, PLM5113

10

PLM5113
PLM5113
PLM5113
PLM5113

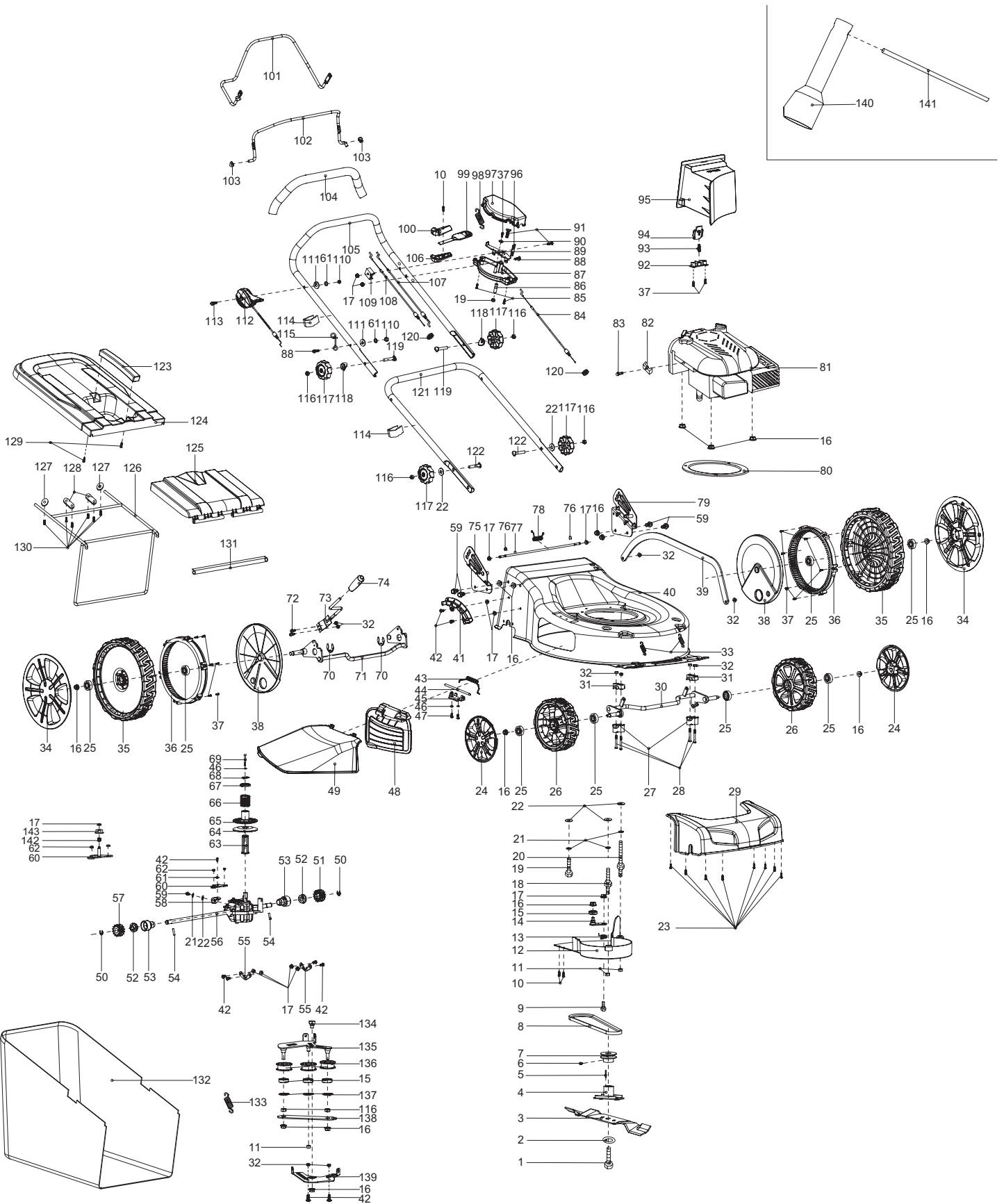

PLM4120, PLM4620,
PLM4621, PLM4622,
PLM4623, PLM5113

10

PLM5113
PLM5113
PLM5113
PLM5113



Seite / Page	Pos.	PLM5113	Teil-Nr. Part No. No. de pièce No. de pieza	Hinweise Notes Renseign. Nota	Bezeichnung	Spezifikation Specification	Description	Désignation	Denominación
10	71	1	671 001 574		HINTERRADACHSE		REAR WHEELS AXLE	AXE ROUE ARRIERES	EJE RUEDAS TRASERAS
10	72	2	671 002 030		SCHRAUBE	M6x14	TRIGGER BOLT	VIS	TORNILLO
10	73	1	671 001 570		HEBEL, HÖHENVERSTELLU NG		LEVER, HEIGHT ADJUSTMENT	LEVIER, REGLAGE HAUTEUR	PALANCA, AJUSTE ALTURA
10	74	1	671 001 031		HEBEL, HÖHENVERSTELLU NG UND GRIFFUMHÜLLUNG KPL.	INC. 73, 74	LEVER, HEIGHT ADJUSTMENT CPL.	LEVIER, REGLAGE HAUTEUR CPL.	PALANCA, AJUSTE ALTURA CPL.
10	75	1	671 001 325		GRIFFANBINDUNG, RECHTS	Makita	BRACKET HANDLE, RIGHT	BRIDE DE POIGNÉE, DROITE	FIJACIÓN DE MANGO, DERECHA
10	76	2	671 009 017		KLEMMRING		OPEN BLOCK RING	ANNEAU	ANILLO
10	77	1	671 001 518		STANGE GRASKLAPPE		LONG POLE	TRINGLE TRAPPE À HERBE	BARRA TAPA DE YERBA
10	78	1	671 011 101		FEDER		SPRING OF REAR COVER BOARD	RESSORT	MUELLE
10	79	1	671 001 324		GRIFFANBINDUNG, LINKS	Makita	BRACKET HANDLE, LEFT	BRIDE DE POIGNÉE, GAUCHE	FIJACIÓN DE MANGO, IZQ.
10	80	1	671 144 701		GUMMI		RUBBER	CAOUTCHOUC	GOMA
10	81	1			MOTOR	B&S 675 EX ReadyStart	ENGINE	MOTEUR	MOTOR
10	*	1		Pos. 81,82,83	ZUM AUSTAUSCH DIESER TEILE WENDEN SIE SICH AN DEN KUNDENDIENST DES MOTORHERSTELLE RS		TO REPLACE THESE PARTS SEEK ASSISTANCE FROM THE ENGINE MANUFACTURER'S AFTER SALES SERVICE	POUR LE REPLACEMENT DE CES PIÈCES S'ADRESSER AU SERVICE APRÈS VENTES DU CONSTRUCTEUR DU MOTEUR	PARA RECAMBIO DE ESTAS PIEZAS FAVOR SE DIRIGEN AL SERVICIO TÉCNICO DEL FABRICANTE DEL MOTOR
10	84	1	671 011 162		BOWDENZUG, SCHALTUNG		CONTROL CABLE, GEARBOX	CÂBLE BOWDEN, CHANGEMENT DE VITESSE	TRACCIÓN BOWDEN, CAMBIO
10	85	2	671 001 028		SCHRAUBE SELBSTSCHNEIDEN D	4x22	SELF-TAPPING SCREW	VIS DE FORAGE	TORNILLO PERFORADOR
10	86	1	671 001 513		HÜLSE	φ9x32	SLEEVE	DOUILLE	CASQUILLO
10	87	1	671 470 001		GEHÄUSE LINKS		CASE, LEFT	CARTER GAUCHE	CÁRTER IZQ.
10	88	2	671 006 011		SCHRAUBE	M6x35	BOLT	VIS	TORNILLO
10	89	1	671 001 514		ANSCHLUßPLATTE KPL.		CONNECTING BOARD CPL.	PLATINE DE RACCOREMENT CPL.	PLACA DE CONEXIONES CPL.
10	90	1	671 002 075		SCHEIBE	φ12/4.5x1.0	WASHER	RONDELLE	ARANDELA
10	91	2	671 006 063		6KT-SCHRAUBE	M6x40	HEXAGON BOLT	VIS À SIX PANS	TORNILLO HEXAGONAL
10	92	1	671 317 001		DRUCKPLATTE		PRESSING PLATE	PLAQUE	PLACA
10	93	1	671 011 005		FEDER	φ8.0*φ0.9*31mm	SPRING	RESSORT	MUELLE
10	94	1	671 316 004		VERRIEGELUNGSK NOPF		LOCKING BUTTON	TÊTE DE VERROUILLAGE	BOTÓN DE BLOQUEO
10	95	1	671 509 001		MULCHEINSATZ		MULCHING BLOCK	INSERT MULCH	TAPA
10	96	1	671 001 511		FIXIERBLECH		FIXED PLATE	FIXATION	FIJACIÓN
10	97	1	671 470 002		GEHÄUSE RECHTS		CASE RIGHT	CARTER DROIT	CÁRTER DER.
10	98	1	671 011 123		FEDER		SPRING OF SPEED ADJUSTMENT WHEEL	RESSORT	MUELLE
10	99	1	671 001 458		HEBEL		LEVER	LEVIER	PALANCA
10	100	1	671 471 001		GRIFFSCHALE, LINKS		GRIP PLATE, LEFT	PLAQUE DE POIGNÉE, GAUCHE	CHAPA DE MANGO, IZQ.
10	101	1	671 001 731		HEBEL, ANTRIEB		LEVER, DRIVING	LEVIER TRACTION	PALANCA, CONDUCCIÓN
10	102	1	671 001 448		HEBEL, MOTORBREMSE		LEVER, MOTOR BRAKE	LEVIER FREIN MOTEUR	PALANCA, FRENO MOTOR
10	103	2	671 001 524		DRUCKPLATTE		PRESSING PLATE	PLAQUE	PLACA

PLM4120, PLM4620,
PLM4621, PLM4622,
PLM4623, PLM5113

10

PLM5113
PLM5113
PLM5113
PLM5113

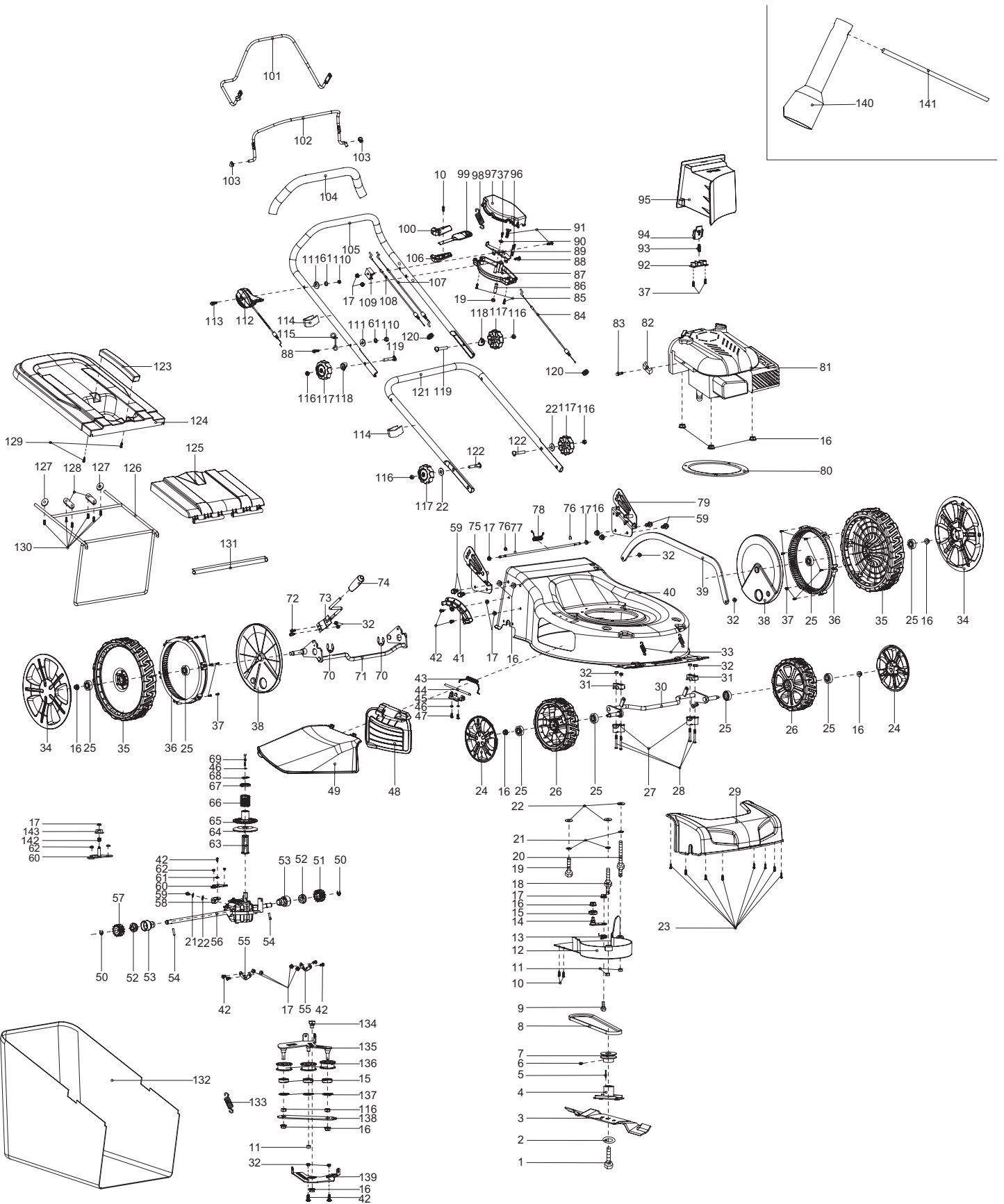

PLM4120, PLM4620,
PLM4621, PLM4622,
PLM4623, PLM5113

10

PLM5113
PLM5113
PLM5113
PLM5113



Seite / Page	Pos.	PLM5113	Teil-Nr. Part No. No. de pièce No. de pieza	Hinweise Notes Renseign. Nota	Bezeichnung	Spezifikation Specification	Description	Désignation	Denominación
10	104	1	671 001 017		GRIFFUMHÜLLUNG		HANDLE SHEATH	POIGNÉE	EMPUÑADURA
10	105	1	671 001 497		HOLM, OBERTEIL		HANDLE, UPPER PART	MANCHERON, PARTIE SUPERIEURE	MANILLAR, PARTE SUPERIOR
10	106	1	671 471 002		GRIFFSCHALE, RECHTS		GRIP PLATE, RIGHT	PLAQUE DE POIGNÉE, DROITE	CHAPA DE MANGO, DERECHA
10	107	1	671 001 151		BOWDENZUG (MOTORBREMSE)		CONTROL CABLE (MOTOR BRAKE)	CÂBLE BOWDEN (FREIN MOTEUR)	TRACCIÓN BOWDEN (FRENO MOTOR)
10	108	1	671 001 115		BOWDENZUG (RADANTRIEB)	18"	CONTROL CABLE (WHEEL DRIVE)	CÂBLE BOWDEN (ENTRAÎNEMENT DE ROUE)	TRACCIÓN BOWDEN (TRACCIÓN DE RUEDA)
10	109	1	671 336 001		HALTERUNG		FIXED BRACKET	FIXATION	SOPORTE
10	110	2	671 005 016		6KT-MUTTER	M6	HEX. LOCK NUT	ECROU	TUERCA
10	111	2	671 007 008		SCHEIBE	φ16xφ8x0,8	WASHER	RONDELLE	ARANDELA
10	112	1	671 001 150		MOTORFERNBEDIE NUNG INKL. BOWDENZUG		HANDLE / CABLE, THROTTLE	LEVIER / CABLE, ACCELERATEUR	PALANCA / CABLE, ACELERADOR
10	113	1	671 006 059		SCHRAUBE	M6x50	BOLT	VIS	TORNILLO
10	114	2	671 177 001		KABELCLIPP		CABLE CLIP	CLIP DE CÂBLE	CLIP PARA CABLE
10	115	1	671 001 647		HAKEN		CABLE HOOK	TENON	GANCHO
10	116	6	671 005 007		MUTTER	M8	NUT	ECROU	TUERCA
10	117	4	671 453 001		STERNGRIF		STAR KNOB	MANETTE	MANIJA DE ESTRELLA
10	118	2	671 001 085		SCHEIBE		WASHER	RONDELLE	ARANDELA
10	119	2	671 006 004		FLACHKOPFSCHRAUBE	M8x52	FLAT HEAD BOLT	VIS À TÊTE CYLINDRIQUE	TORNILLO DE CABEZA PLANA
10	120	2	671 178 001		GUMMITÜLLE		CORD PROTECTING SHEATH	PASSE-FIL	BOQUILLA DE CAUCHO
10	121	1	671 001 453		HOLM, UNTERTEIL		HANDLE, LOWER PART	MANCHERON, PARTIE INFÉRIEURE	MANILLAR, PARTE INFERIOR
10	122	2	671 006 118		FLACHKOPFSCHRAUBE	M8x35	FLAT HEAD BOLT	VIS À TÊTE CYLINDRIQUE	TORNILLO DE CABEZA PLANA
10	123	1	671 454 001		HANDGRIF		HANDLE OF GRASS CATCHER	POIGNÉE	MANGO
10	124	1	671 521 001		KORB, OBERTEIL		GRASS-BOX, UPPER	SAC, PARTIE	CESTO, SUPERIOR
10	125	1	671 468 001		HECKKLAPPE		REAR COVER BOARD	HAYON	PORTÓN TRASERO
10	126	1	671 001 443		RAHMEN		GRASS CATCHER BRACKET	CADRE	MARKO
10	127	2	671 001 436		SCHEIBE	φ5*φ24*2	TIGHTEN PRESSING PLATE	RONDELLE	ARANDELA
10	128	2	671 001 203		DRUCKPLATTE		PRESSING PLATE OF FRONT WHEEL AXLE	PLAQUE	PLACA
10	129	2	671 001 055		SCHRAUBE SELBSTSCHNEIDEN D	5x16	SELF-TAPPING SCREW	VIS DE FORAGE	TORNILLO PERFORADOR
10	130	6	671 001 054		SCHRAUBE SELBSTSCHNEIDEN D	5x12	SELF-TAPPING SCREW	VIS DE FORAGE	TORNILLO PERFORADOR
10	131	1	671 001 353		DRUCKLEISTE		PRESSING BAR	BARRE	LISTÓN
10	132	1	671 144 401		NYLONEINSATZ FÜR FANGKORB	65L Nylon Makita Logo	GRASS CATCHER	SAC	CESTO
10	133	1	671 011 021		FEDER		SPRING	RESSORT	MUELLE
10	134	1	671 003 042		FIXIERSCHRAUBE		FIXED BOLT	VIS	TORNILLO
10	135	1	671 001 455		SPANNROLLENHALTER		FIXED BOARD OF SPEED ADJUSTMENT WHEEL	SUPPORT	SOPORTE

PLM4120, PLM4620,
PLM4621, PLM4622,
PLM4623, PLM5113

10

PLM5113
PLM5113
PLM5113
PLM5113

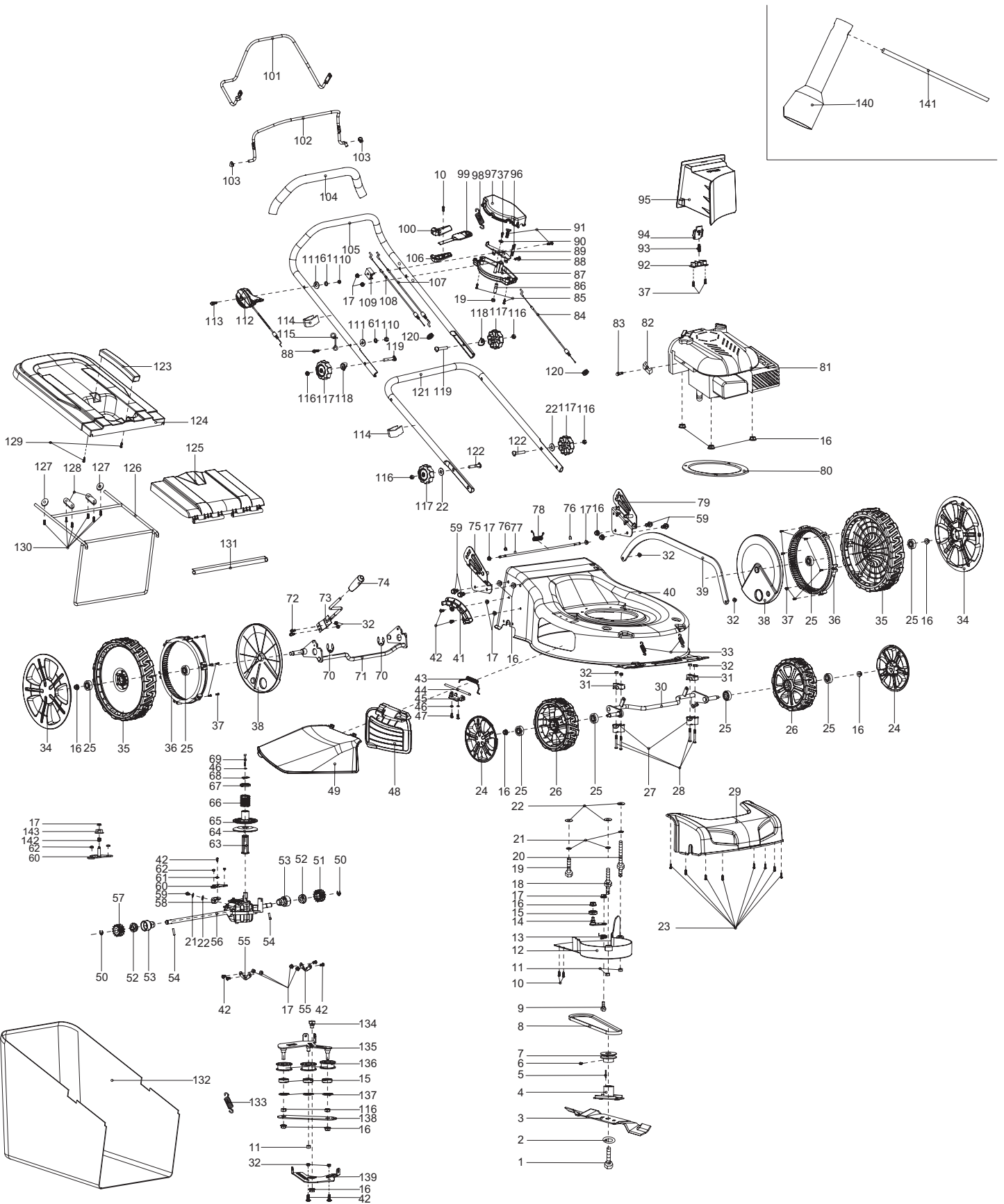

PLM4120, PLM4620,
PLM4621, PLM4622,
PLM4623, PLM5113

10

PLM5113
PLM5113
PLM5113
PLM5113



Seite / Page	Pos.	PLM5113	Teil-Nr. Part No. No. de pièce No. de pieza	Hinweise Notes Renseign. Nota	Bezeichnung	Spezifikation Specification	Description	Désignation	Denominación
10	136	3	671 001 056		RIEMENSCHLEIBE		PULLEY	POULIE À GORGE POUR COURROIE	DISCO DE LA CORREA
10	137	3	671 009 021		RING	φ28	RING	ANNEAU	ANILLO
10	138	1	671 001 533		DRUCKPLATTE		PRESSING PLATE OF FIXED BOARD	PLAQUE	PLACA
10	139	1	671 001 456		HEBEL		LEVER	LEVIER	PALANCA
10	140	1	671 001 078		STECKSCHLÜSSEL	21mm	BOX SPANNER	CLÉ À DOUILLE	LLAVE
10	141	1	671 001 079		SPANNSTANGE	Φ8x110mm	SPANNER POLE	TIRANT	TENSOR
10	142	1	671 011 156		FEDER		SPRING	RESSORT	MUELLE
10	143	1	671 002 038		HÜLSE		SHAFT SHEATH	DOUILLE	CASQUILLO