

# TECHNICAL INFORMATION



PRODUCT

P 1/19

**Model No.** ▶ HR4013C, HR4003C

**Description** ▶ 40mm (1-9/16") Rotary Hammer

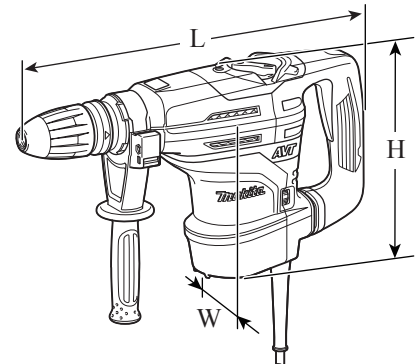

(The image above is HR4013C.)

## CONCEPT AND MAIN APPLICATIONS

Model HR4013C/HR4003C are the successor models of the current HR4011C series models and developed to provide higher operating efficiency and more comfort with unrivalled low level of vibration, the optional dust extractor attachment newly designed, etc.

Listed below are the specification differences between HR4013C and HR4003C.

		HR4013C	HR4003C
AVT*	Active dynamic vibration absorber	Yes	No
	Vibration absorbing housing	Yes	No
	Soft no load	Yes	No

\*Anti-Vibration Technology

Dimensions: mm (")		
	HR4013C	HR4003C
Length (L)	479 (18-11/16)	
Width (W)	112 (4-3/8)	106 (4-3/16)
Height (H)	263 (10-3/8)	

## ► Specification

Voltage (V)	Current (A)	Cycle (Hz)	Continuous Rating (W)		Max. Output (W)
			Input	Output	
110	12	50/60	1,100	500	1,200
120	11	50/60	---	500	1,200
220	6.2	50/60	1,100	550	1,500
230	6.2	50/60	1,100	550	1,500
240	6.2	50/60	1,100	550	1,500

Specification			Model	HR4013C	HR4003C
No load speed: min. <sup>-1</sup> = rpm				250 - 500	
Impacts per minute: min. <sup>-1</sup> = ipm				1,450 - 2,900	
Shank type				Adapted for SDS-MAX	
Capacity: mm (")	Concrete	TCT bit		40 (1-9/16)	
		Core bit		105 (4-1/8)	
Electronic features	Variable speed control switch			Yes	
	Soft start			Yes	
	Constant speed control			Yes	
	Soft no load			Yes	No
Torque limiter				Yes	
Protection from electric shock				Double insulation	
Power supply cord: m (ft)				Europe: 4.0 (13.1), Brazil, Chile, Peru: 2.0 (6.6), Other countries: 5.0 (16.4)	
Weight according to EPTA-Procedure 01/2003*: kg (lbs)				6.8 (15.1)	6.2 (13.8)

\* With Side handle (Bar style)

## ► Standard equipment

- Depth gauge (Stopper pole) .....1
- Side handle assembly (D-shaped) .....1
- Side handle (Bar style) .....1
- Bit grease .....1
- Cleaning cloth .....1
- Plastic carrying case .....1

**Note:** The standard equipment for the tool shown above may vary by country.

## ► Optional accessories

- Assorted TCT drill bits
- Assorted Bull points
- Assorted Scaling chisels
- Grooving chisel
- Bushing tool
- Scoop
- Chemical anchor adaptor
- Hammer grease
- Bar style side handle
- Syringe
- Dust extractor attachment
- Assorted Core bits
- Assorted Cold chisels
- Scaling chisel (for Tile)
- Shank (for Bushing tool and Rammer)
- Rammer
- Side handle assembly (D-shaped)
- Bit Grease
- Safety Goggle
- Plastic carrying case
- Hammer Service Kit

## ► Repair

**CAUTION: Repair the machine in accordance with “Instruction manual” or “Safety instructions”.**

### [1] NECESSARY REPAIRING TOOLS

Code No.	Description	Use for
1R003	Retaining ring S pliers ST-2N	removing Ring spring 25 from Tool holder expanding the ends of Torsion spring 7
1R022	Bearing plate (for arbor press)	removing Helical gear 38
1R027	Bearing setting pipe 18-10.2	assembling Torque limiter
1R032	Bearing setting plate 8.2	supporting Crank housing for assembling Cylinder to the inside
1R045	Gear extractor (large)	removing Armature from Gear housing complete
1R165	Ring spring setting tool B	assembling Crank section to Crank housing and Connecting rod
1R212	Tip for Retaining ring pliers	Attachment of 1R003
1R213	Cylinder extractor	disassembling Cylinder from Crank housing
1R214	Taper sleeve	fitting Fluoride ring 25 to Impact bolt
1R238	Round bar for Arbor 9-100	removing Crank shaft
1R258	V block	assembling Crank section to Crank housing
1R269	Bearing extractor	removing Ball bearings
1R291	Retaining ring S and R pliers	removing Retaining Ring S-8
1R306	Ring spring removing jig	removing Crank shaft
1R312	Hammer vise	supporting the machine
1R350	Ring 60 (3 pcs.)	disassembling Cylinder from Crank housing
1R363	Ring spring removing tool	removing Ring spring 25
1R400	Spring fixing jig	disassembling Cylinder from Crank housing

### [2] LUBRICATION

Apply the following grease to protect parts and product from unusual abrasion.

\* Makita grease R No.00 to the portions indicated by **black triangle** ▲

\* Makita grease N No. 2 to the portions indicated by **gray triangle** ▲

#### Barrel and Tool holder section

Item No.	Description	Grease	Portion to lubricate	Amount
①	Tool holder cap	N No.2	Lip portion	
⑳	Tool retainer		Portion where Bit contacts	
⑬	Barrel complete (13a) Oil seal 32 (13b) Plane bearing 32 (13c) Plane bearing 45	R No.00	Inner surface where ⑳ Tool holder contacts	a little
			Bit installation side	
			Crank housing side	
⑰	Flat washer 32			
⑱	Flat washer 32			
㉑	Tool holder		Inner surface where ㉒ Impact bolt contacts	10g
㉒	O ring 20			
㉔	O ring 20		Portion where ㉑ Tool holder contacts	a little
㉖	Impact bolt		Drum portion	

**Fig. 1**

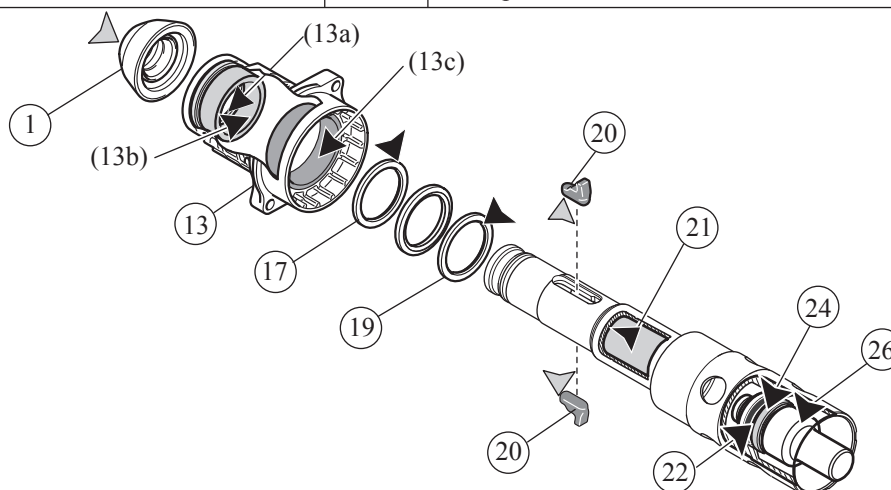

► **Repair**

[2] LUBRICATION (cont.)

**Crank housing and Motor section**

Item No.	Description	Grease	Portion to lubricate	Amount
(31)	O ring 22 on Striker	R No.00	Whole portion	a little
(42)	Cylinder 28.5		Inside between Striker and Piston	10g
(44)	O ring 30 (3 pcs.)		Revealed surface from Cylinder	a little
(47)	O ring 21 on Piston		Whole portion	
(48)	O ring 22 on Piston		Whole portion	
(49)	Connecting rod		Hole for Crank shaft pin	
(52)	Spiral bevel gear 26		Gear teeth	
(78)	Crank housing complete		Inner periphery of Plane bearing 54 (78a) (The component of Crank housing complete) Crank room (78b)	20g
(95)	Gear housing complete		Gear teeth of Torque limiter, Helical gear 37 and Armature	20g
(96)	Oil seal 15		Lip portion	a little

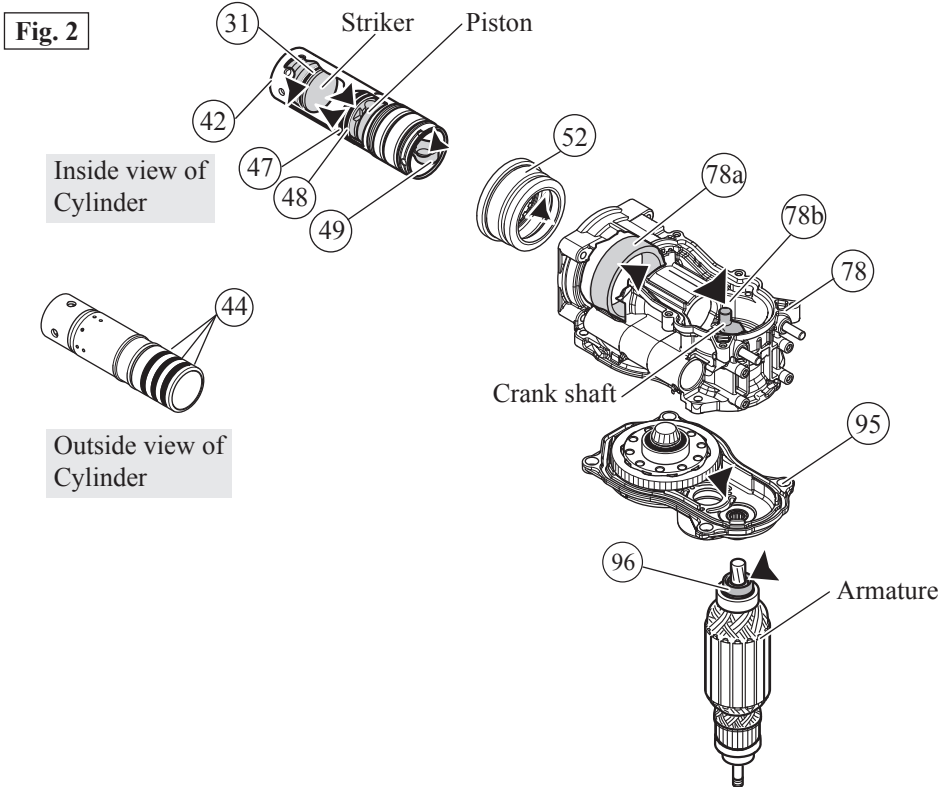

**AVT mechanism (for HR4013C only)**

Item No.	Description	Grease	Portion to lubricate	Amount
(55)	Counter weight	R No.00	Drum portion	a little

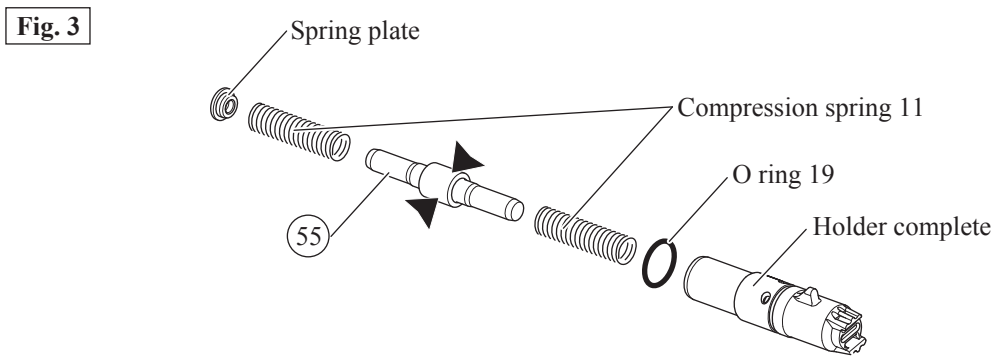

# Repair

## [3] DISASSEMBLY/ASSEMBLY

### [3]-1. Chuck

#### DISASSEMBLING

Chuck section can be disassembled as drawn in **Fig. 4**.

**Fig. 4**

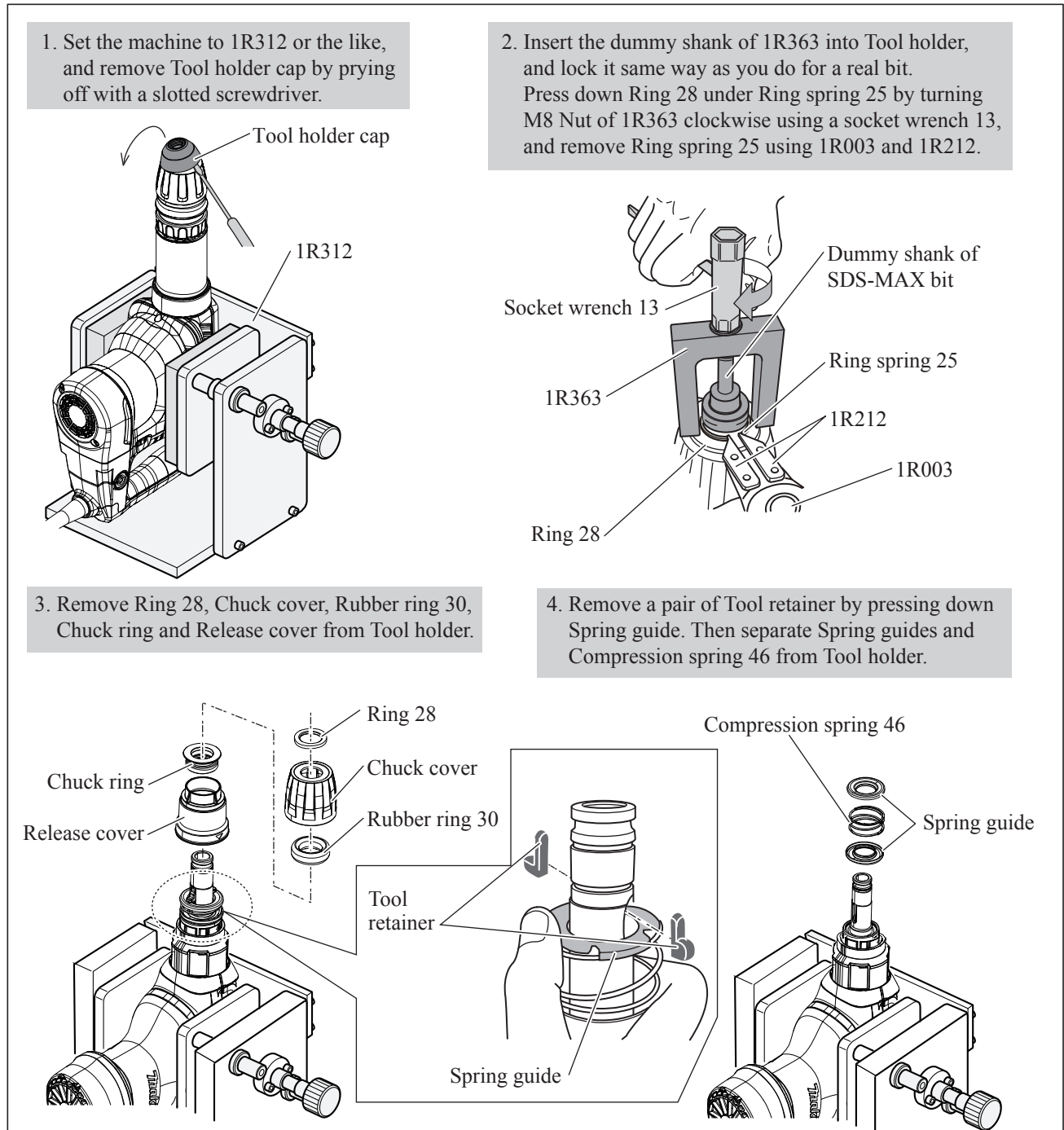

#### ASSEMBLING

Assemble Chuck section by reversing the disassembly procedure. Refer to **Fig. 4**.

**Note:** It is difficult to set Tool holder cap in place by hand. Put Tool holder cap on floor, and push Tool holder of the machine to the cap while making use of the machine weight.

**Fig. 5**

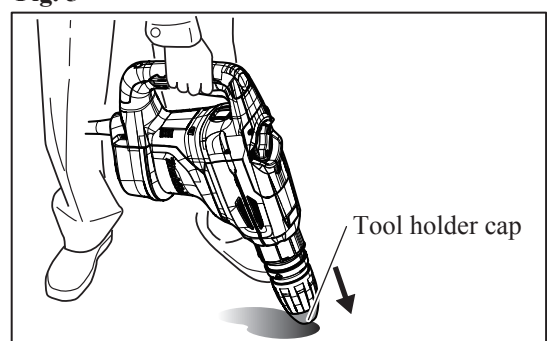

► **Repair**  
**[3] DISASSEMBLY/ASSEMBLY**  
**[3]-2. Impact bolt, Striker**

**DISASSEMBLING**

- (1) Impact bolt, Striker Piston can be disassembled without removing Chuck section. See Fig. 6.
- (2) Striker is removed from Crank housing side as drawn in Fig. 7.

**Fig. 6**

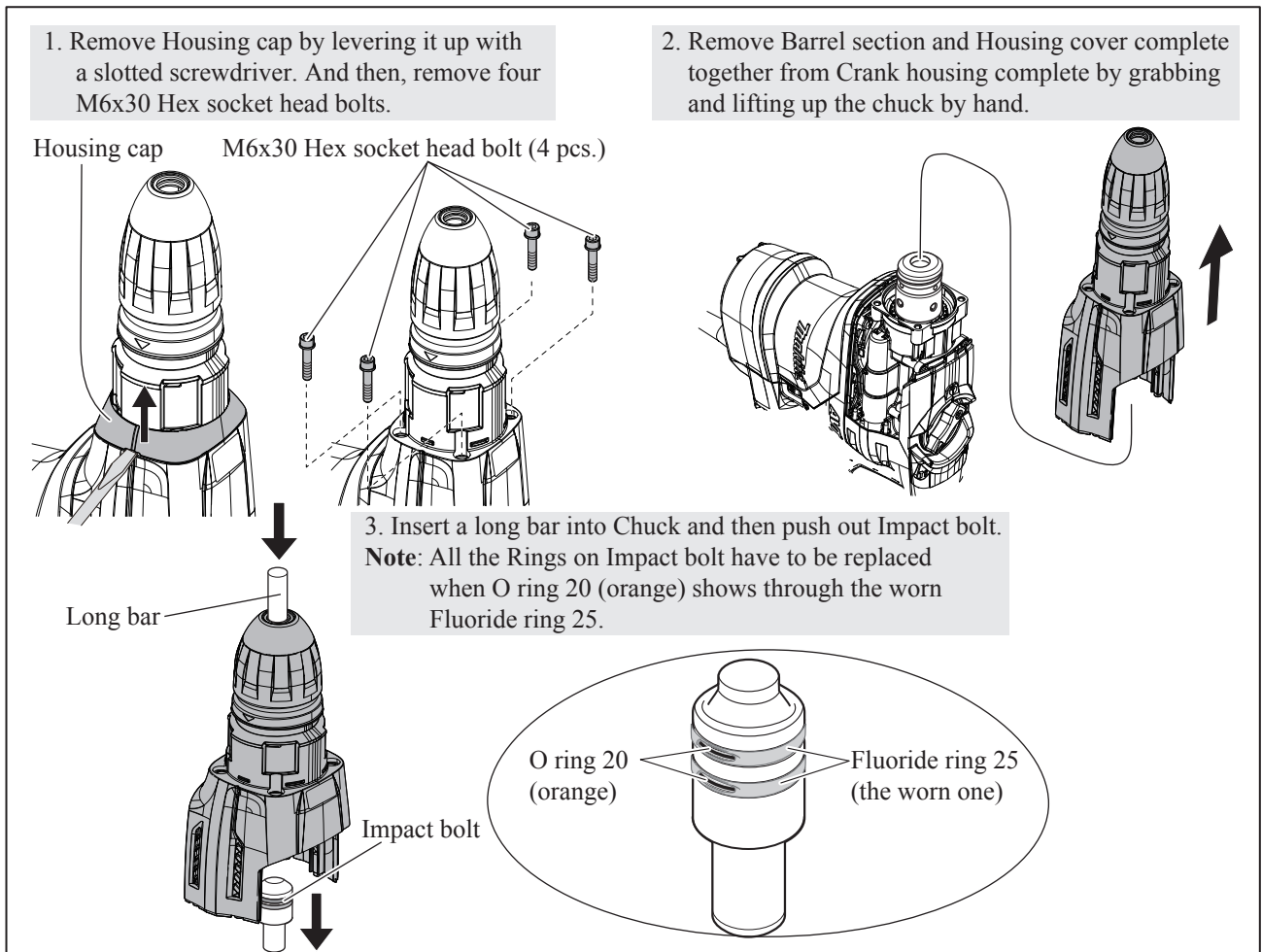

**Fig. 7**

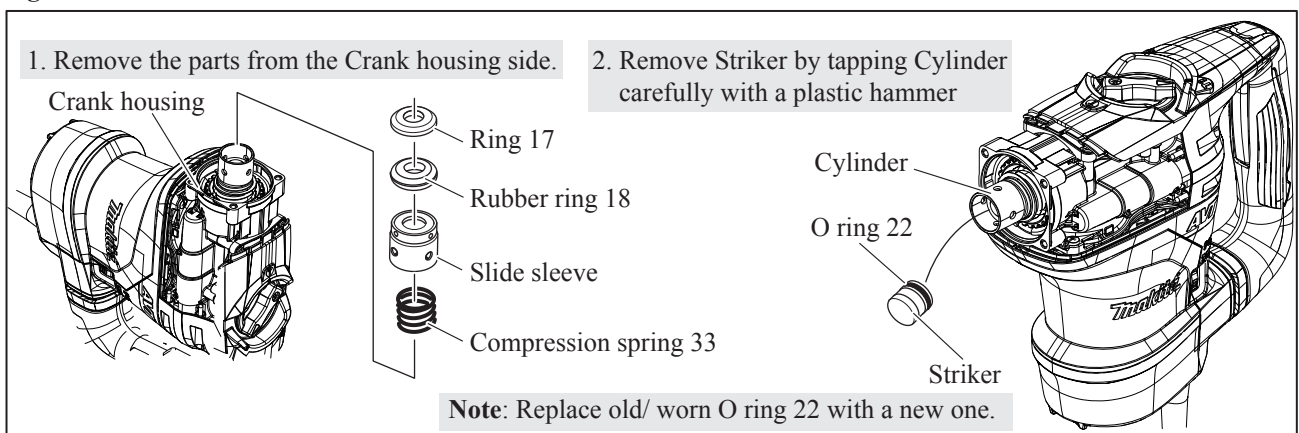

► **Repair**  
**[3] DISASSEMBLY/ASSEMBLY**  
**[3]-2. Impact bolt, Striker (cont.)**

ASSEMBLING

(1) Assemble O rings and Fluoride rings to Impact bolt as drawn in **Fig. 8**.

**Fig. 8**

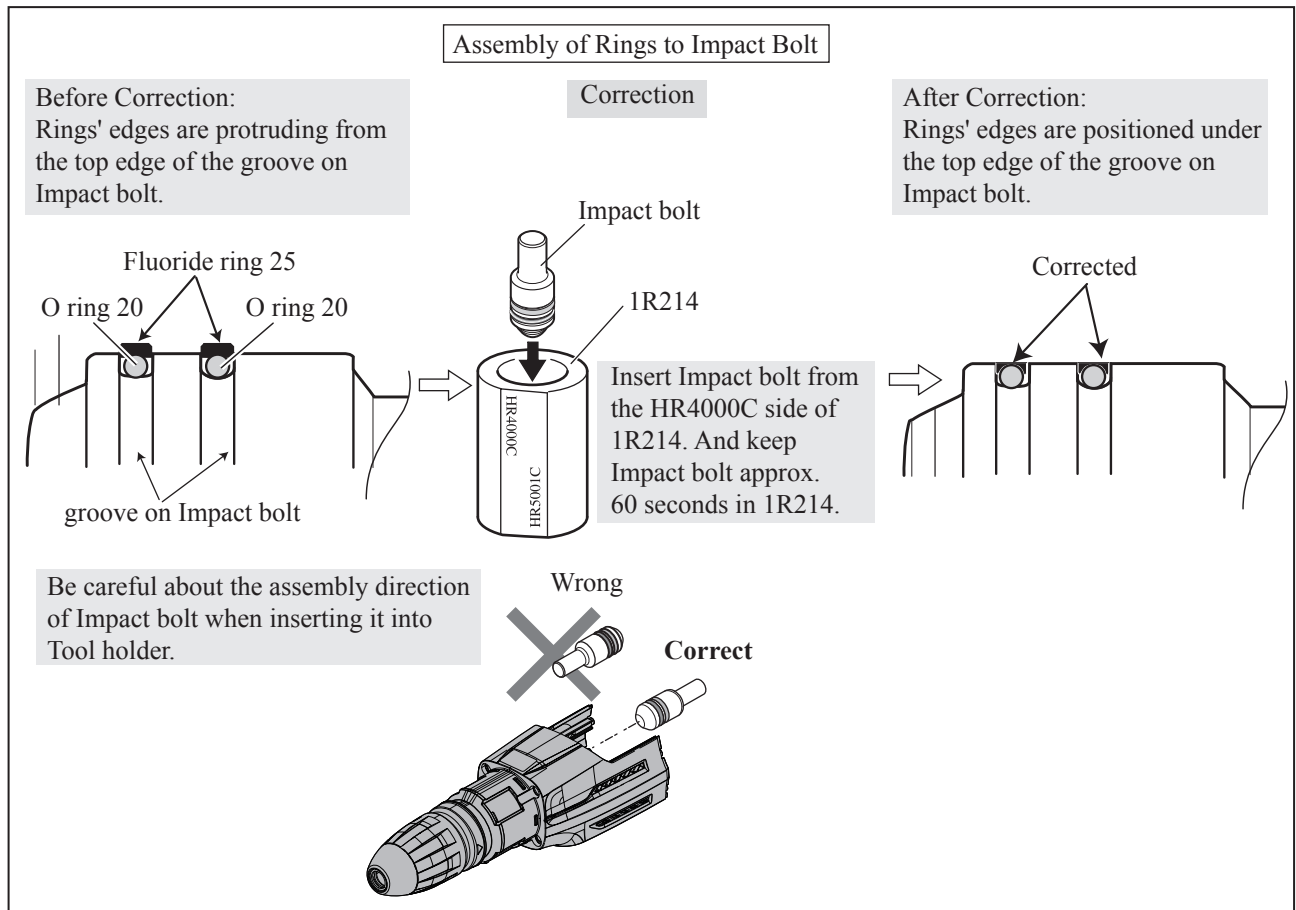

(2) Assemble Striker section as drawn in **Fig. 9**.

**Fig. 9**

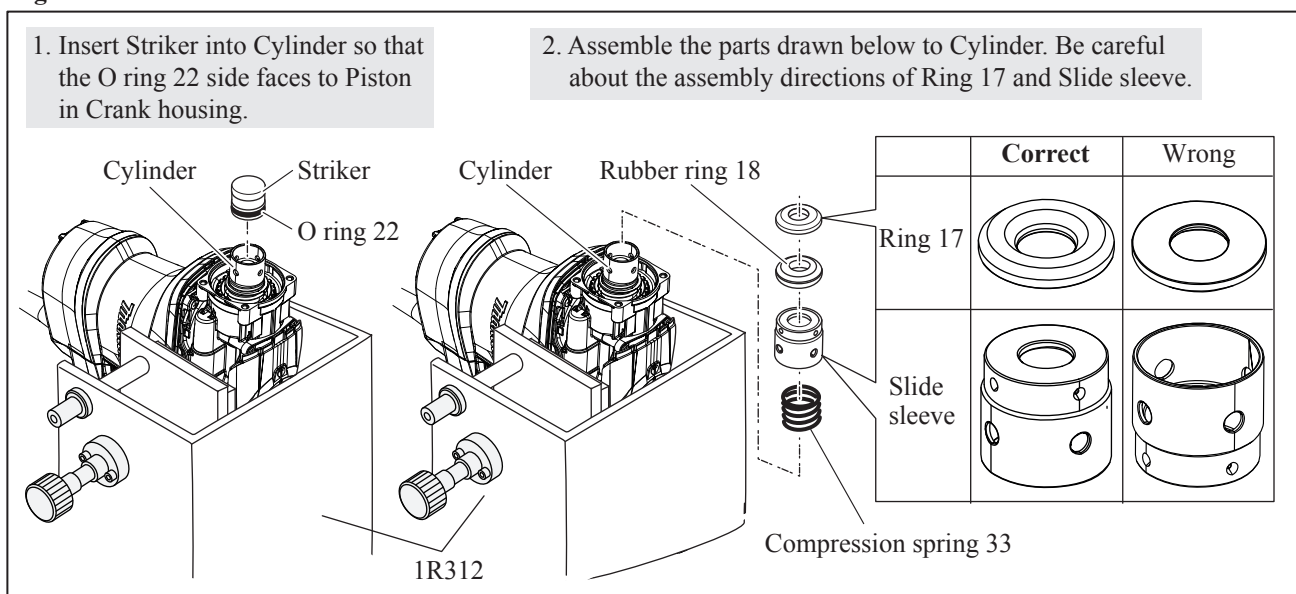

(3) Assemble Barrel section to Cylinder. Refer to **Fig. 6**.

## ► Repair

### [3] DISASSEMBLY/ASSEMBLY

#### [3]-3. Crank housing, Cylinder, Counter weight

##### DISASSEMBLING

(1) After removing Barrel section as drawn in **Fig. 6**, disassemble Handle section as drawn in **Fig. 10**.

**Fig. 10**

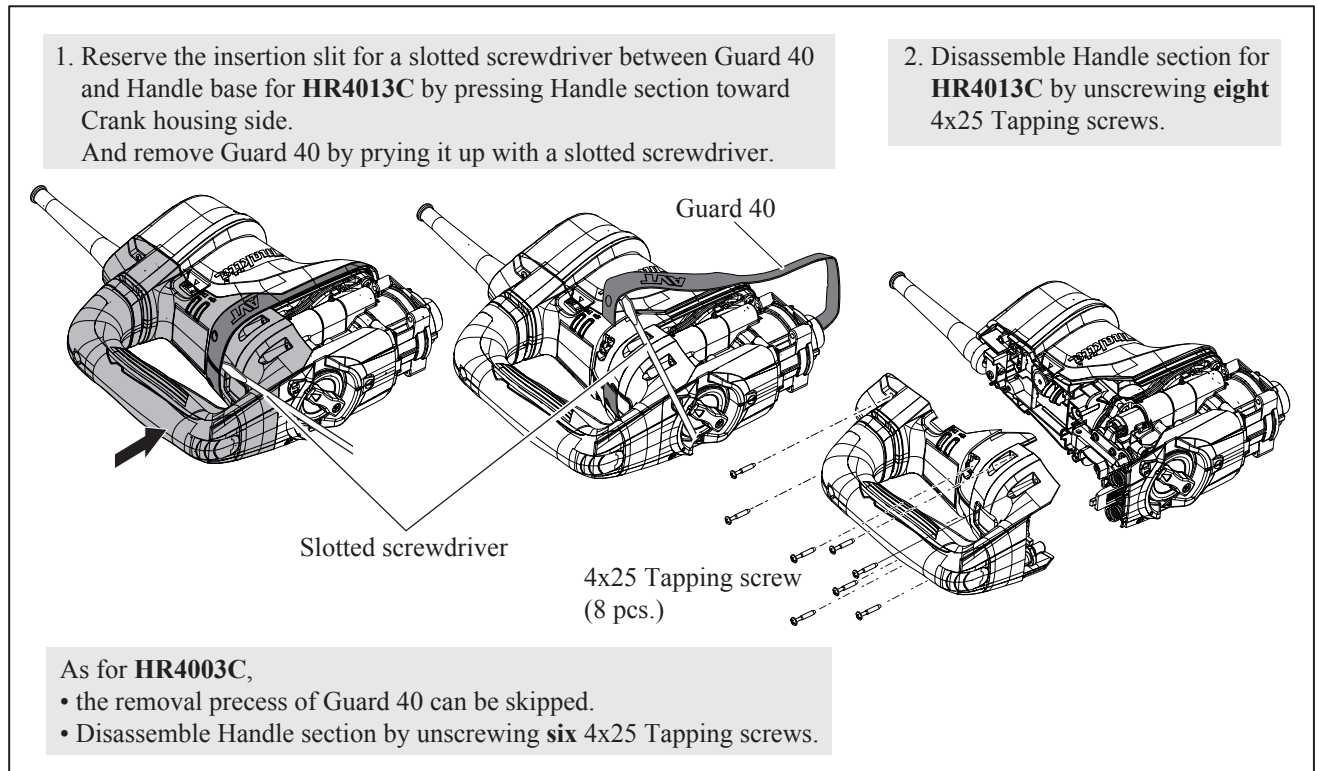

(2) Remove six M4x16 Pan head screws and Crank cap.

While expanding the ends of Torsion spring 7 with 1R003, remove Flat fillister head pin 6 on Link plate. (**Fig. 11**)

**Fig. 11**

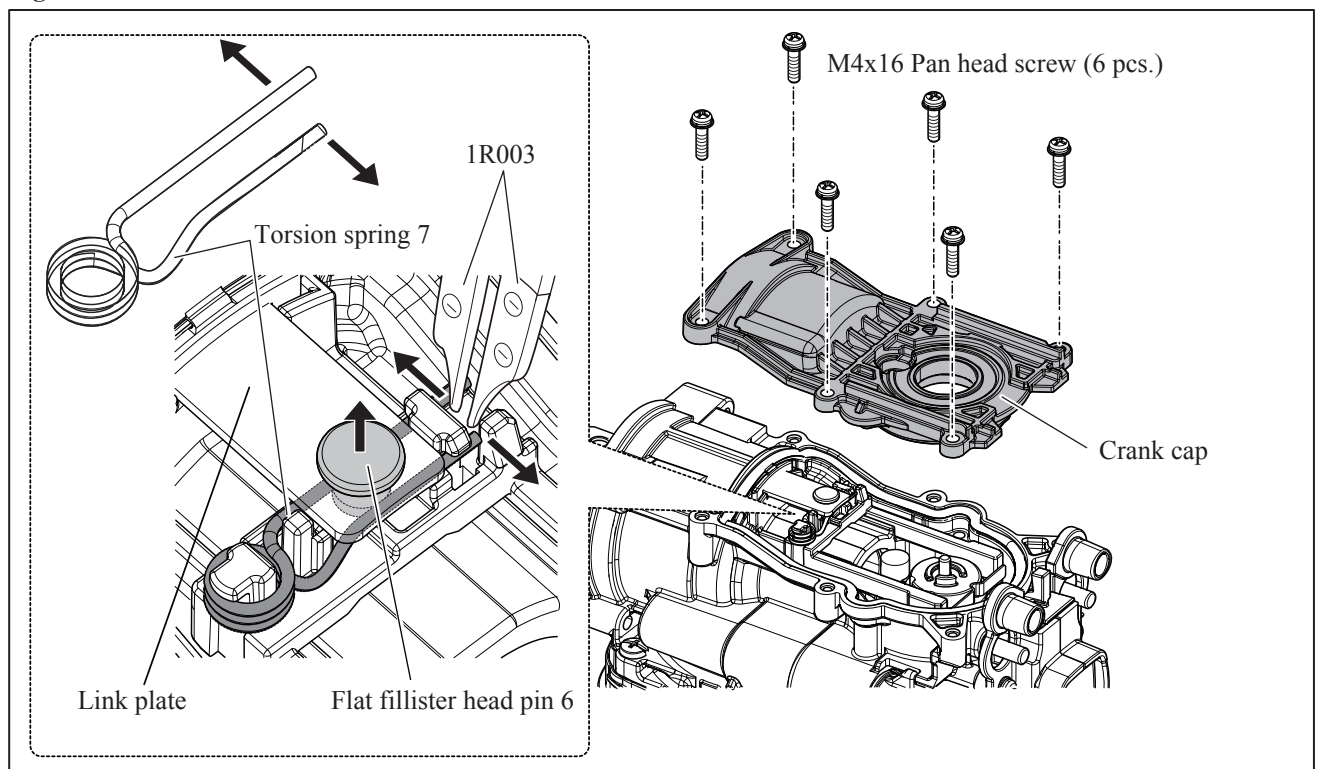

► **Repair**

[3] **DISASSEMBLY/ASSEMBLY**

[3]-3. **Crank housing, Cylinder, Counter weight**

(3) Remove Drive sleeve by pushing the end of Link plate from Crank side. Then, remove Guide ring. (Fig. 12)

Fig. 12

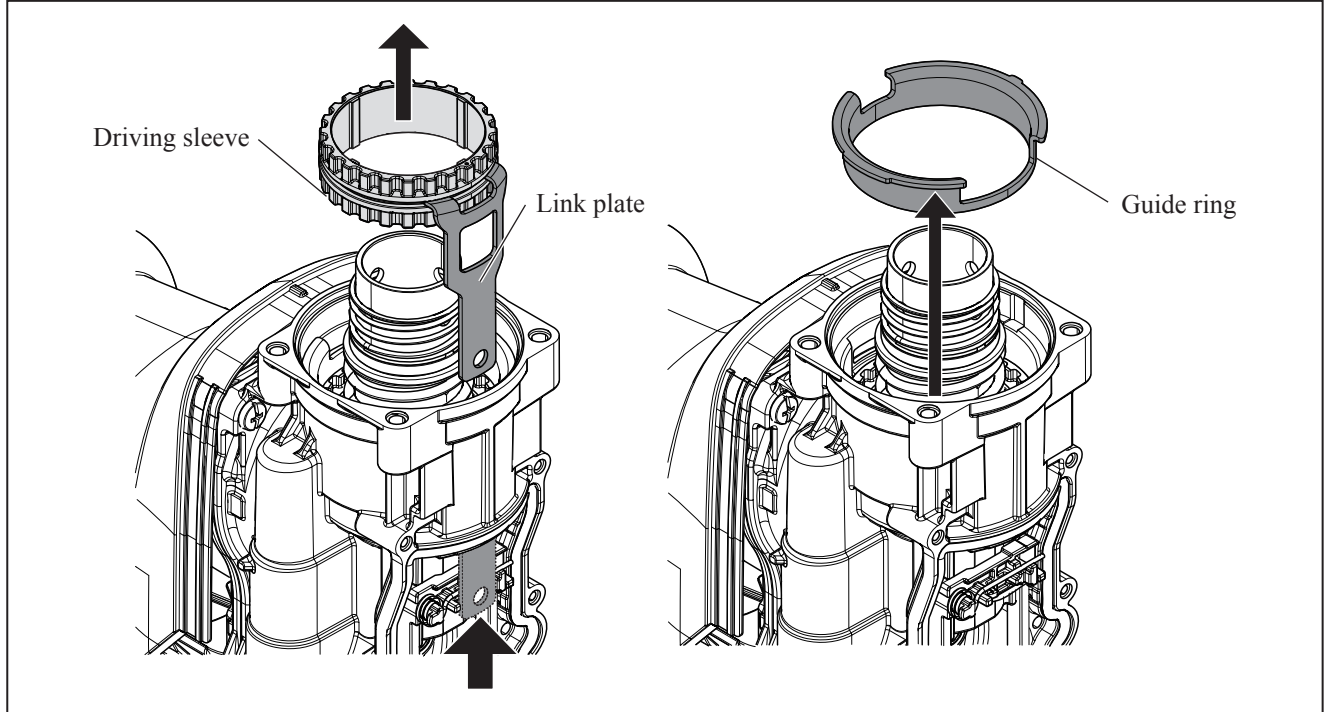

(4) Put three pieces of 1R350 on Crank housing complete, and then remove Cylinder from Crank housing with 1R213 through the holes of the three pieces of 1R350. (Fig. 13)

(5) Remove Spiral bevel gear 26 from Crank housing carefully so as not to be tilted. (Fig. 14)

When Spiral bevel gear 26 is tilted in Crank housing in the disassembly process;

- it is impossible to remove Spiral bevel gear 26.
- Plane bearing 54 in Crank housing is harmed.

Fig. 13

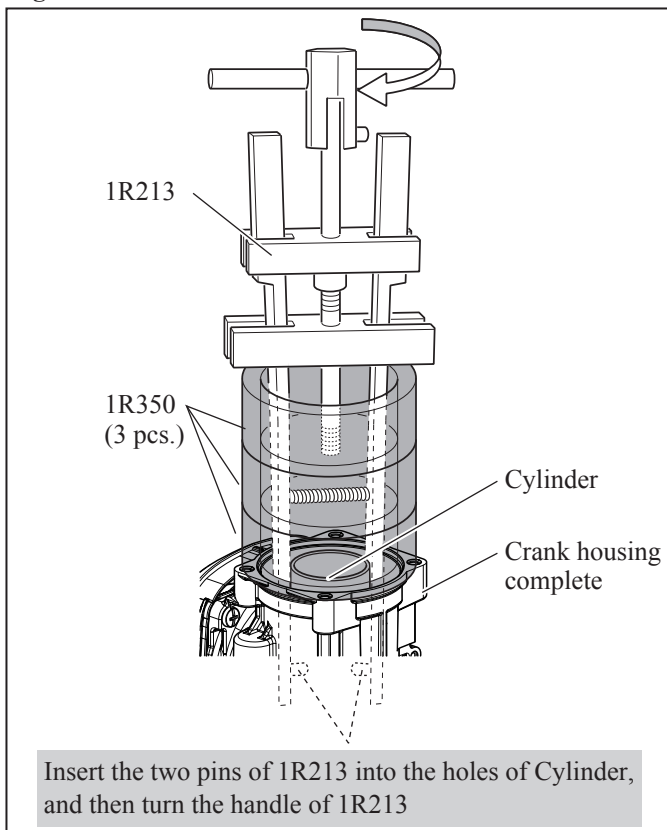
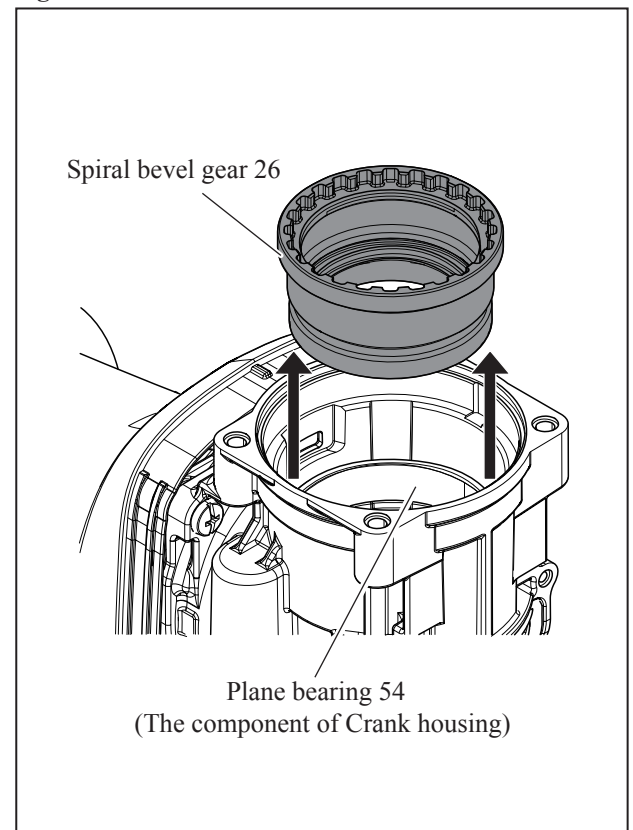

Fig. 14





► **Repair**

**[3] DISASSEMBLY/ASSEMBLY**

**[3]-3. Crank housing, Cylinder, Counter weight (cont.)**

- (6) Put 1R400 on Flat washer 33 located on Chuck side of Cylinder. Assemble two pieces of 1R022 to 1R306. Set 1R306 to Arbor press. Then compress Compression spring 34 by pressing down 1R400 using Arbor press with 1R022 and 1R306 until Retaining ring (EXT) WR-32.5 is revealed, and remove it with 1R003 with 1R212. (Fig. 15)
- (7) Return Compression spring 34 back to the original shape gradually by reducing the pressure. Cylinder section is disassembled as drawn in Fig. 16.

**Fig. 15**

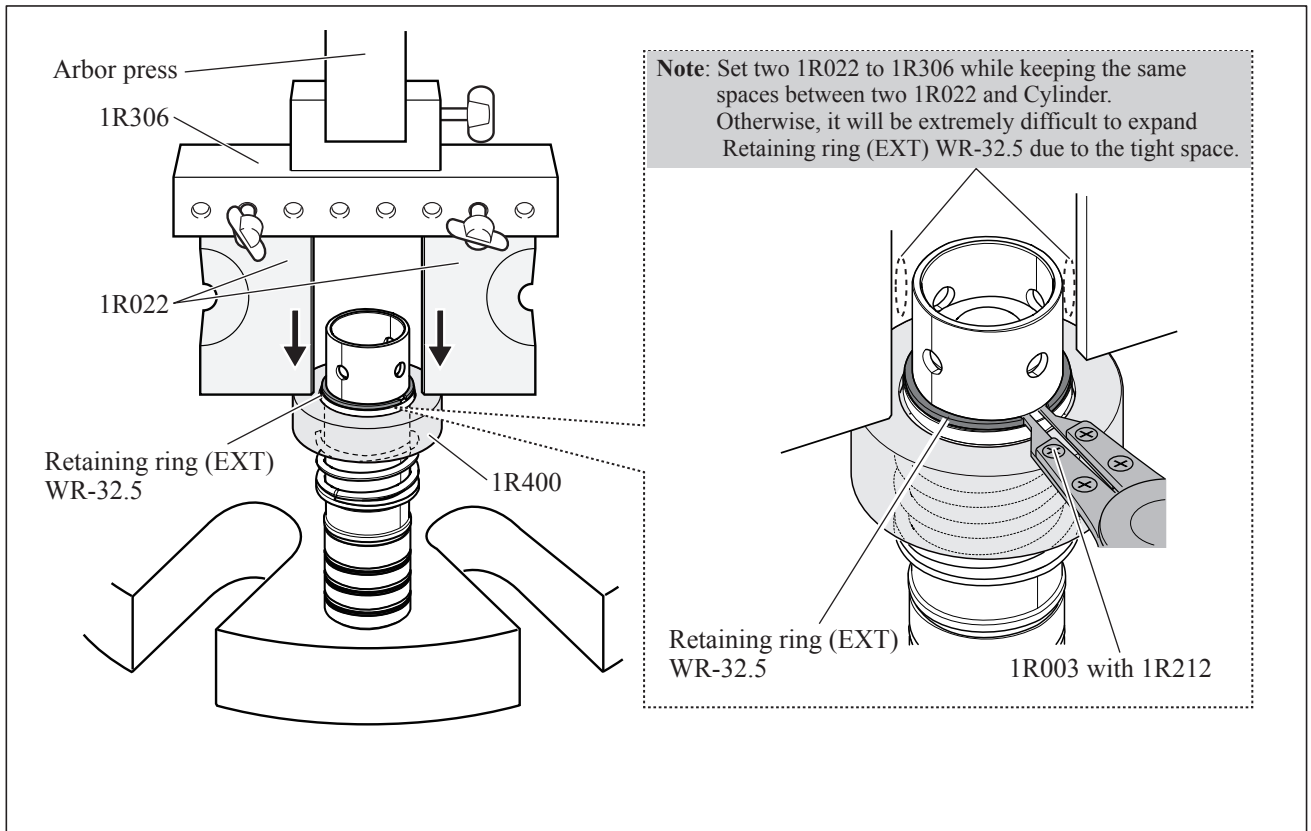

**Fig. 16**

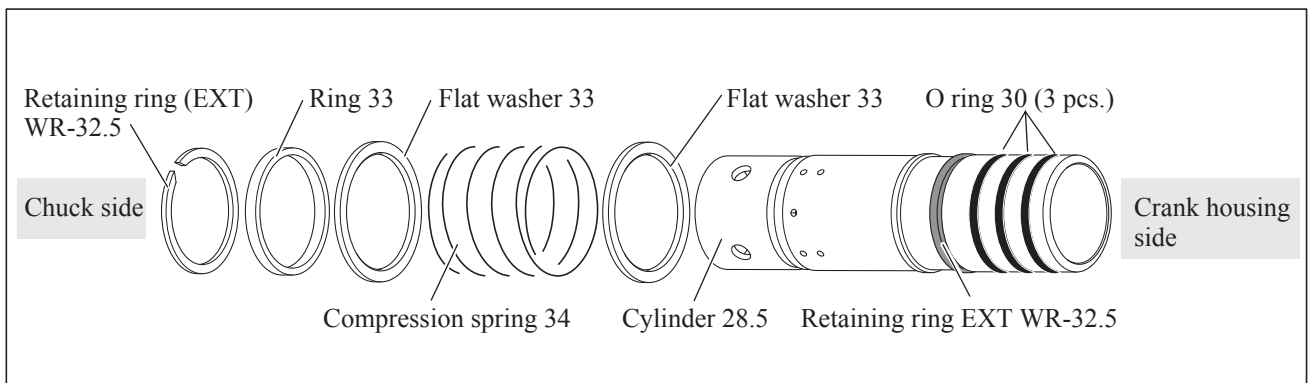

► **Repair**

**[3] DISASSEMBLY/ASSEMBLY**

**[3]-3. Crank housing, Cylinder, Counter weight (cont.)**

- (8) As for model **HR4013C**, loosen four M4x16 Pan head screws and remove Switch case set from Crank housing. (**Fig. 17**)  
Then, Push and Turn each Holder complete on both sides of Crank housing with a slotted screwdriver to remove counter weight mechanism. (**Fig. 18**)
- (9) Loosen four 5x25 Tapping screws and then remove Crank housing and Gear housing from Motor housing. (**Fig. 19**)
- (10) Move the pin portion of Crank shaft to the closest position to Handle side. (**Fig. 20**)  
Put two pieces of 1R238 on Crank shaft as drawn in **Fig. 21**, then hold 1R238 to 1R306 on Arbor press.  
Press down Crank shaft together with Ball bearing 6004LLU, Retaining ring S-20 and Helical gear 10. (**Fig. 21**)
- (11) Connecting rod with Piston section can be removed from Cylinder side. Disassemble Piston section. (**Fig. 22**)

**Fig. 17**

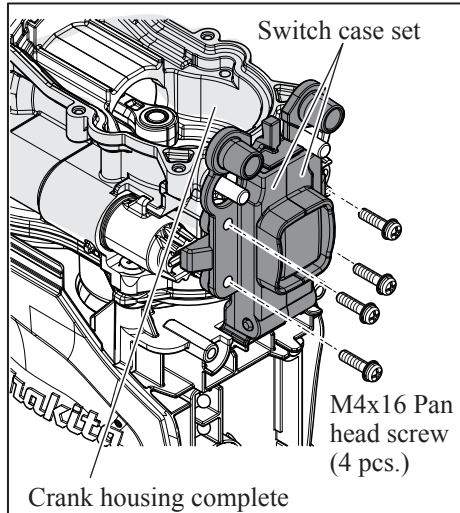

**Fig. 18**

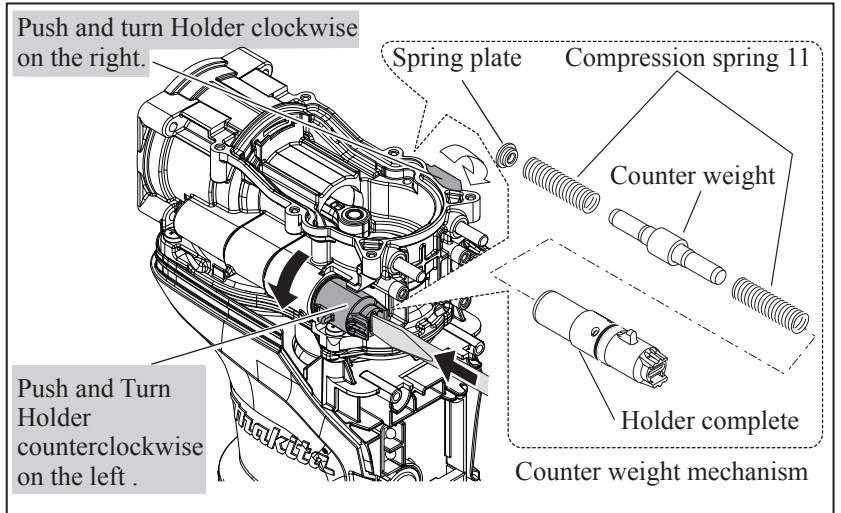

**Fig. 19**

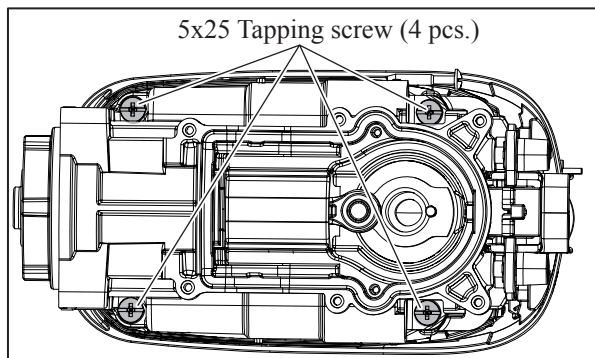

**Fig. 20**

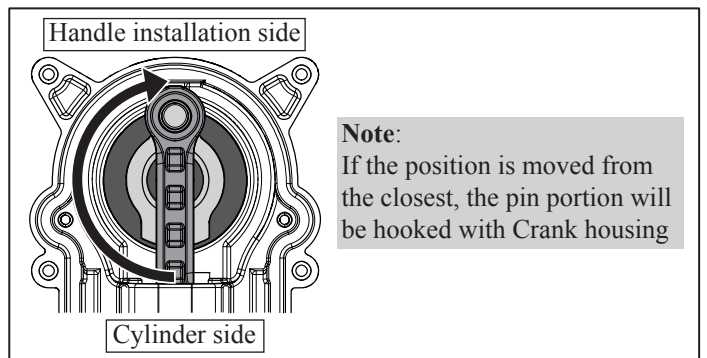

**Fig. 21**

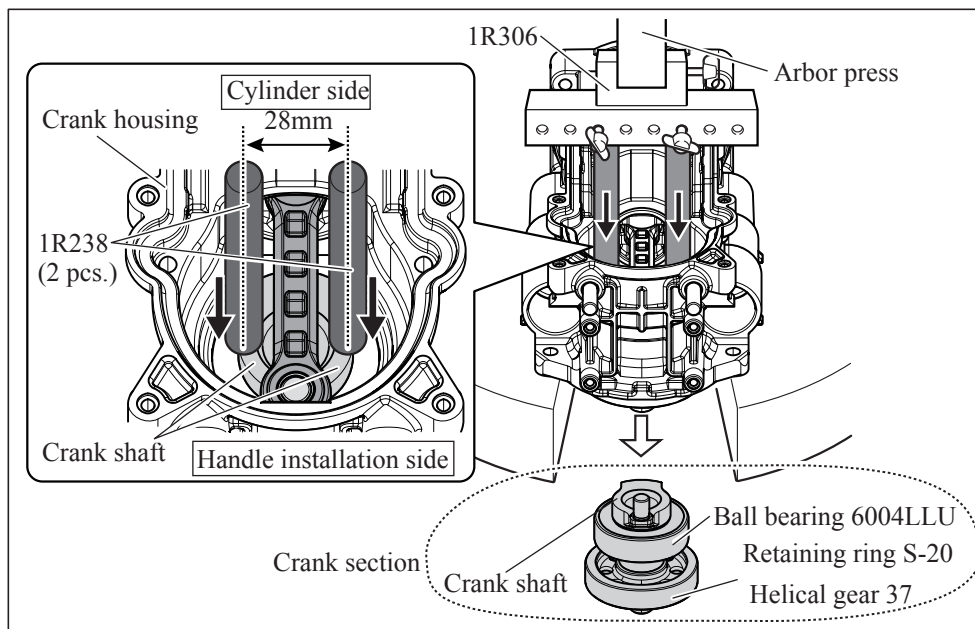

**Fig. 22**

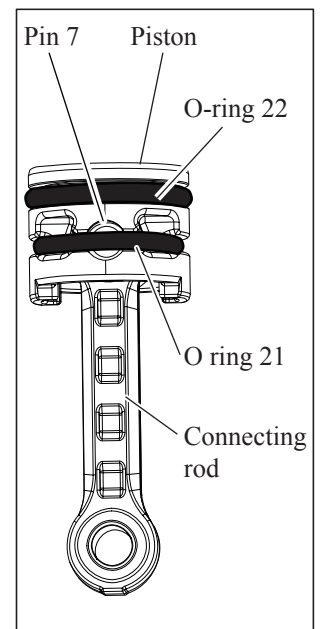

## ► Repair

### [3] DISASSEMBLY/ASSEMBLY

#### [3]-3. Crank housing, Cylinder, Counter weight (cont.)

##### ASSEMBLING

Assemble the components by reversing the disassembly procedure.

- (1) Put Piston section into Crank housing.
- (2) Insert Crank section (drawn in **Fig. 21**) straight into the hole of Crank housing by hand so that the outer periphery of Ball bearing 6004LLU is slightly held in the hole of Crank housing.
- (3) Move the pin of Crank shaft to the closest position to Handle installation side (**Fig. 20**), and turn Crank housing upside down and put on 1R258 with care not to move the pin position. (**Fig. 23**)
- (4) Pressfit Ball bearing 6004LLU in place with 1R165 carefully so as not to cause misalignment between the pin of Crank shaft and the hole of Connecting rod. (**Fig. 24**)
- (5) Turn Crank housing upside down and put 1R165 between Arbor press table and Ball bearing 6004LLU, then fit the pin of Crank shaft into the hole of Connecting rod using 1R306 and Arbor press. (**Fig. 25**)
- (6) Once Oil seal 32 in Barrel complete is removed, using Socket bit 32-50 (Makita part No. 134848-9) makes it easy to pressfit Oil seal 32 in place.

**Fig. 23**

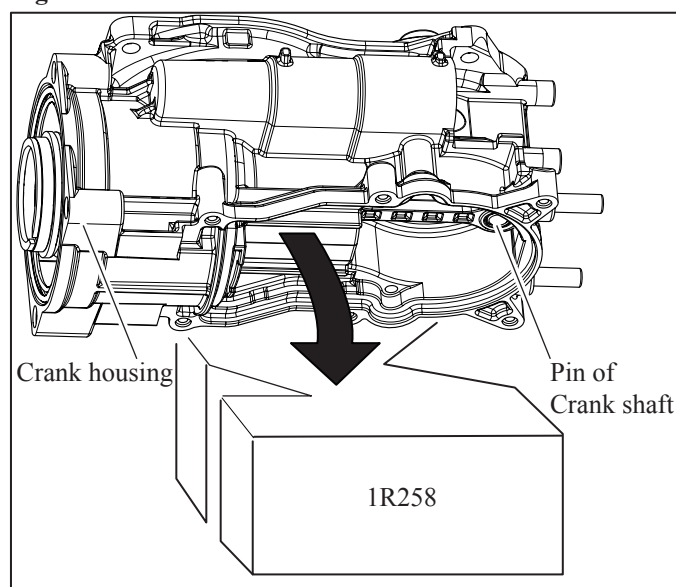

**Fig. 24**

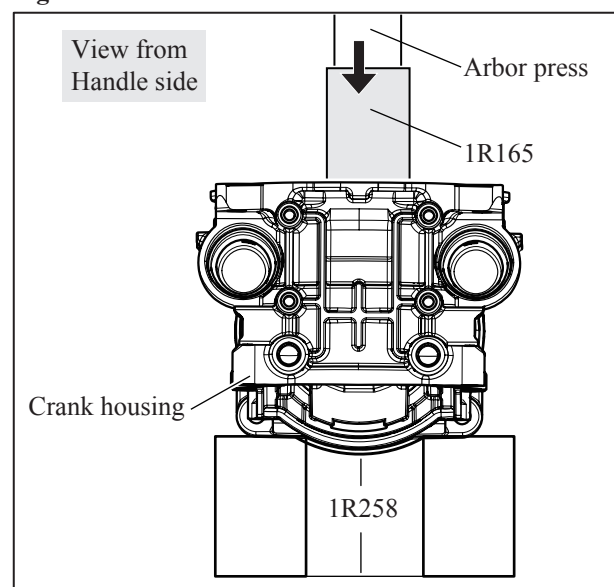

**Fig. 25**

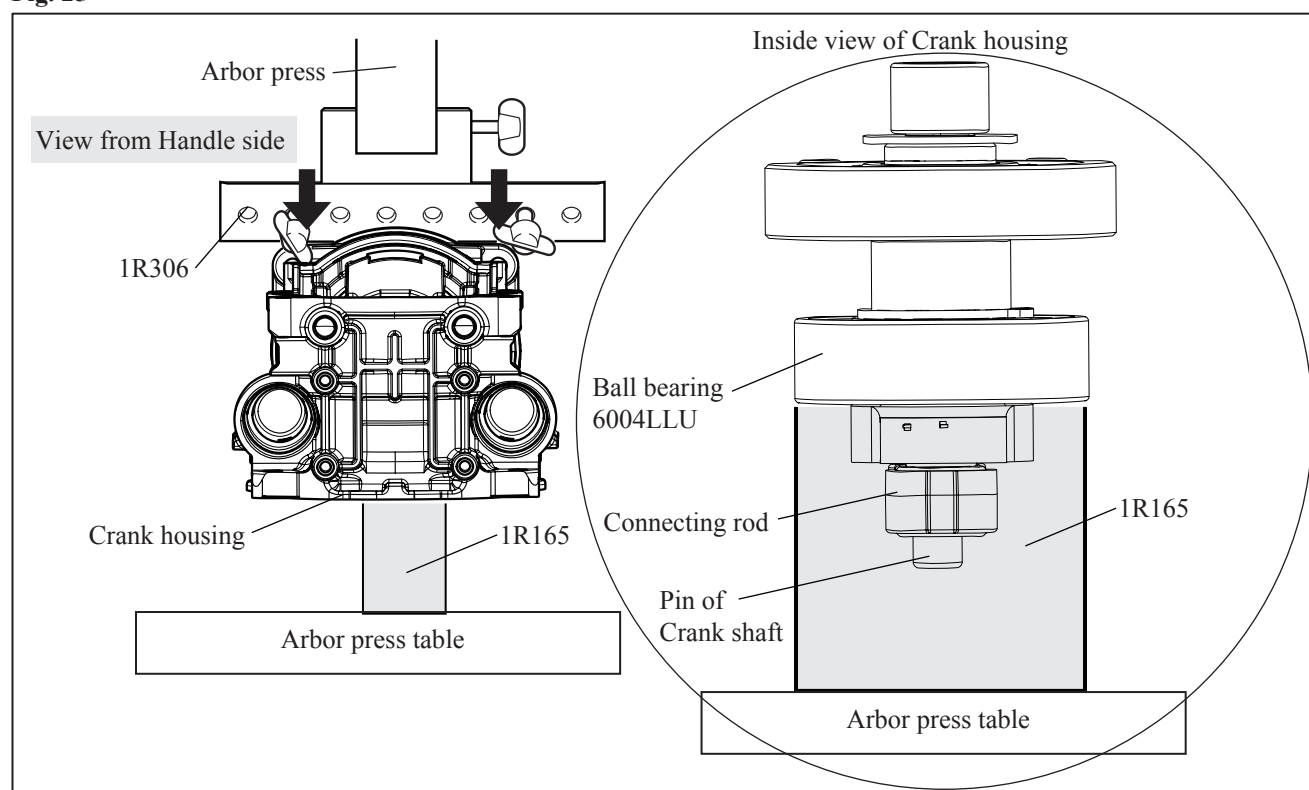

## ► Repair

### [3] DISASSEMBLY/ASSEMBLY

#### [3]-3. Crank housing, Cylinder, Counter weight (cont.)

(7) When Seal ring 8 is removed from Crank housing, be sure to fit Seal ring 8 into the groove of Crank housing before setting Link plate in place.

Fit Seal ring 8 into the groove of Crank housing especially around Link plate, and pass Link plate through the slot in Seal ring 8 from the opposite in advance to make space for the smooth installation of Link plate. Their ways will make it easy to set Link plate in place later. (Fig. 26)

(8) Spiral bevel gear 26 must be installed straight. (Fig. 27) Do not fail to apply Makita grease No. R 00 to the gear teeth.

(9) Three pieces of O ring 30 on Cylinder must be lubricated with Makita grease No. R 00. (Fig. 2 of [2] LUBRICATION) When Cylinder is pressfit into Crank housing, Put 1R032 under the four pins on handle side of Crank housing as drawn in Fig. 28. Place Guide ring in Crank housing as drawn in Fig. 29. Be careful about the direction of Guide ring.

Insert the hooks of Link plate into the center groove of Driving sleeve, and install them into Crank housing. (Fig. 30)

At this time;

- engage the gear teeth of Spiral bevel gear 26 and the cam groove of Driving sleeve.
- pass Link plate through the slot of Seal ring 8.

Fig. 26

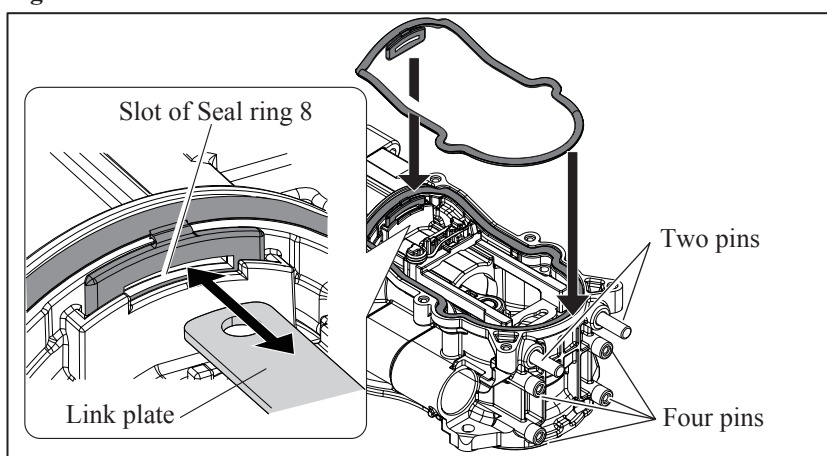

Fig. 27

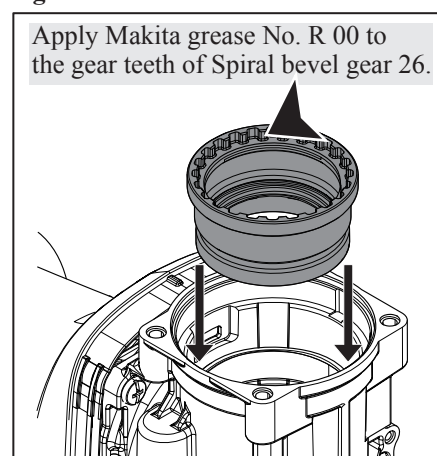

Fig. 28

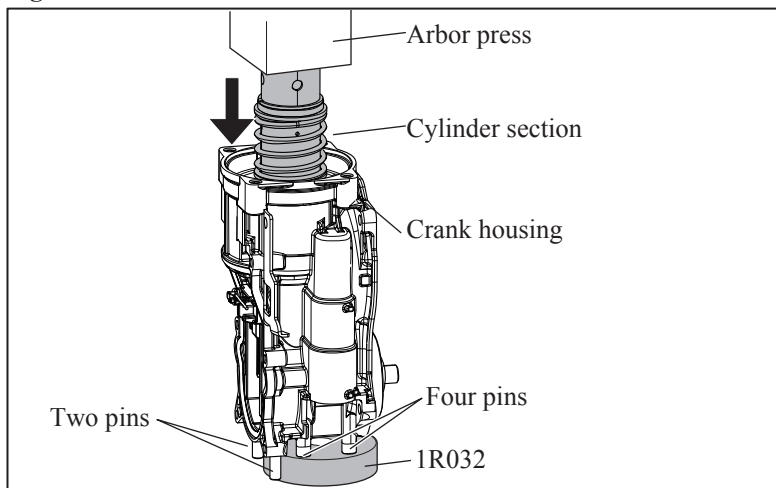

Fig. 29

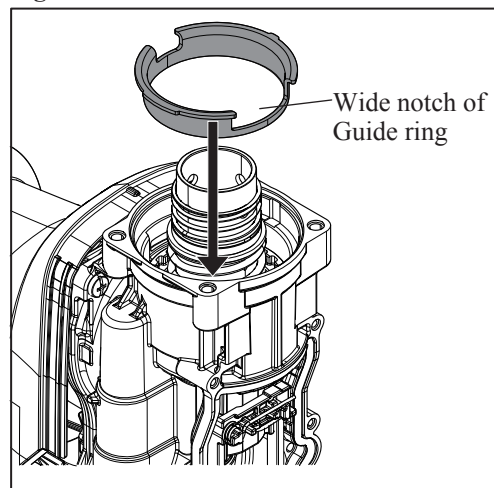
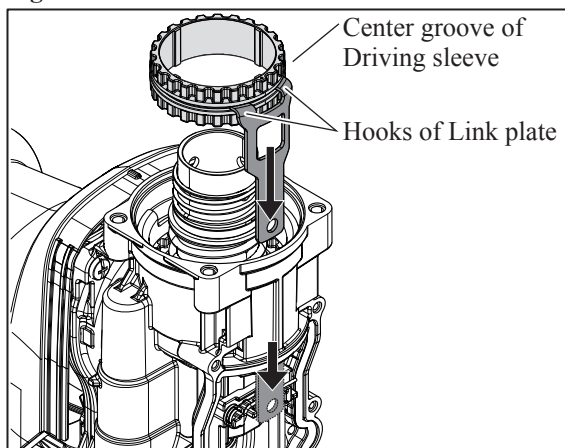

Fig. 30



► **Repair**

**[3] DISASSEMBLY/ASSEMBLY**

**[3]-3. Crank housing, Cylinder, Counter weight (cont.)**

- (10) When Change lever section is disassembled;
  - fit the projection of Leaf spring into the groove on Link lever. (**Fig. 31**)
  - reassemble the components to Crank cap and Housing cover by M4x10 Pan head screw with care to the directions (**Fig. 31**)
  - assemble Crank cap to Crank housing while aligning the pin of Crank cap to the opening of Link guide (**Fig. 32**).
- (11) In the process of reassembling, i.e., as drawn in **Fig. 33**, set Change lever section in place temporarily and turn Change lever counterclockwise and clockwise to check that Driving sleeve moves back and forth.
- (12) When Switch case set and Control plate are set in place;
  - while facing the mark of “>POM-xxxx<” on Control plate to the upper side, pass the projection of Crank lever through the rounded opening of Control plate.
  - pass the square pin of Switch lever C through the long opening of Control plate.

**Fig. 31**

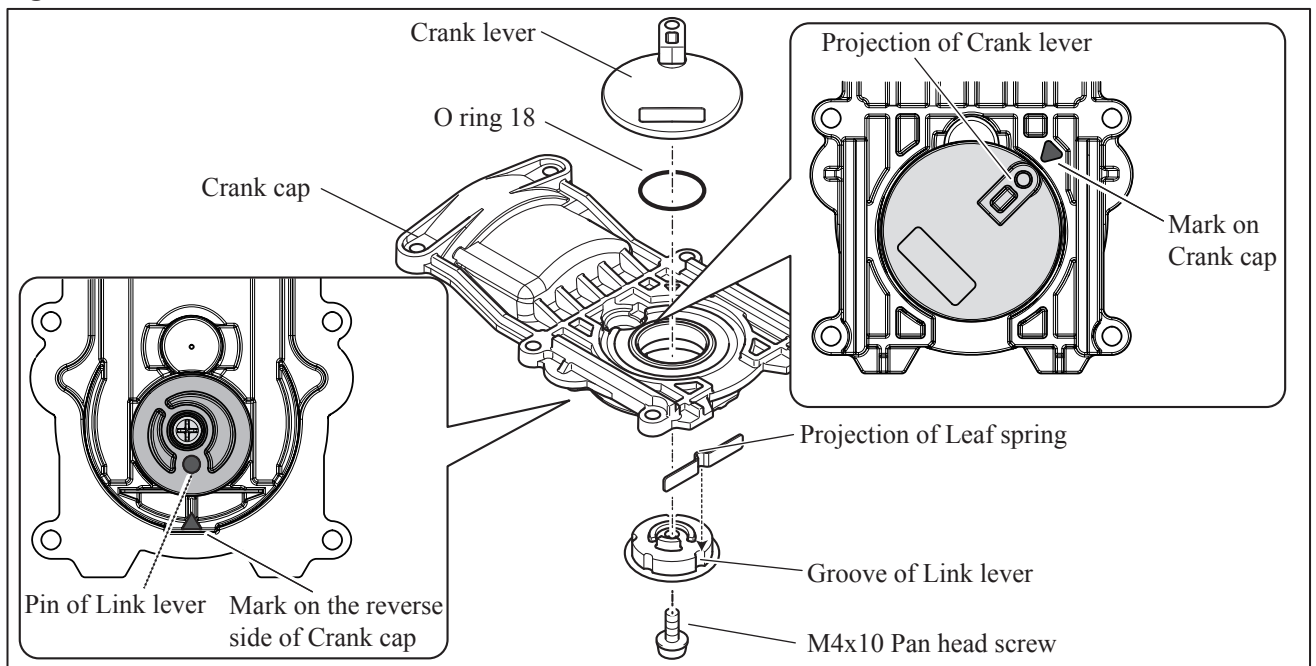

**Fig. 32**

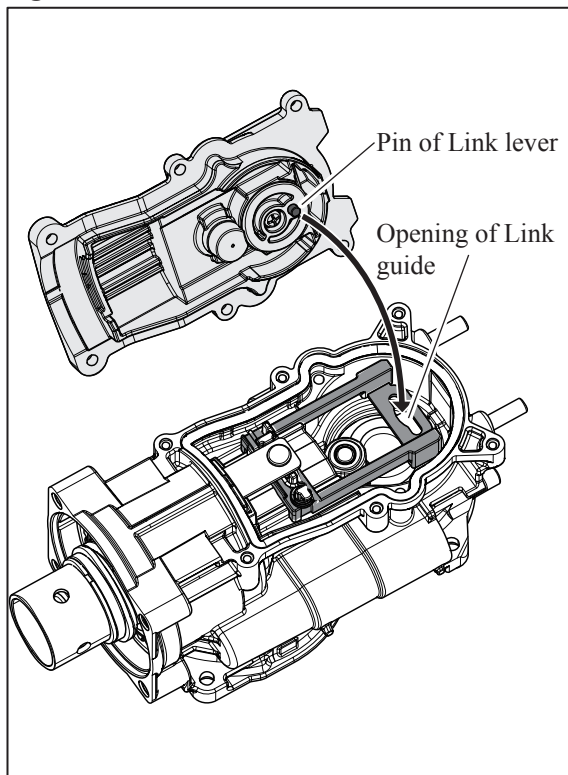

**Fig. 33**

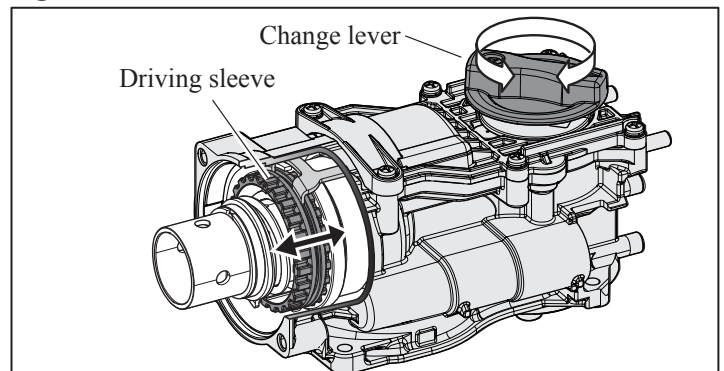

**Fig. 34**

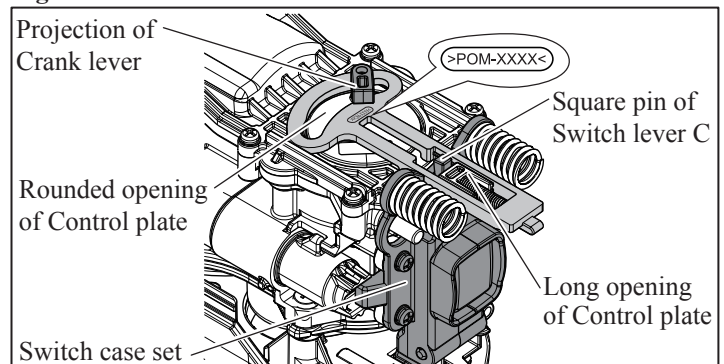

## ► Repair

### [3] DISASSEMBLY/ASSEMBLY

#### [3]-4. Torque limiter assembly

##### DISASSEMBLING

- (1) Remove Gear housing from Crank housing according to [3]-3 of the previous pages.
- (2) Tap Gear housing as drawn in **Fig. 35** with a plastic hammer. Torque limiter assembly is removed.
- (3) Remove Retaining spring S-8 from the shaft of Spiral bevel gear 7 with 1R291. After removing Flat washer 8, separate Ball bearing 608DDW with 1R269. (**Fig. 36**) Shoulder washer 8 is removed.
- (4) Use two 1R258 to receive guide plate portion of Torque limiter complete, press down the shaft of Spiral bevel gear 7. (**Fig. 37**)  
Spiral bevel gear 7, Key 4 (2 pcs.), Ball bearing 6002LLU and Torque limiter complete are removed. (**Fig. 38**)  
**Note:** Do not disassemble Torque limiter complete. Once it is disassembled, it is impossible reassemble them again.

**Fig. 35**

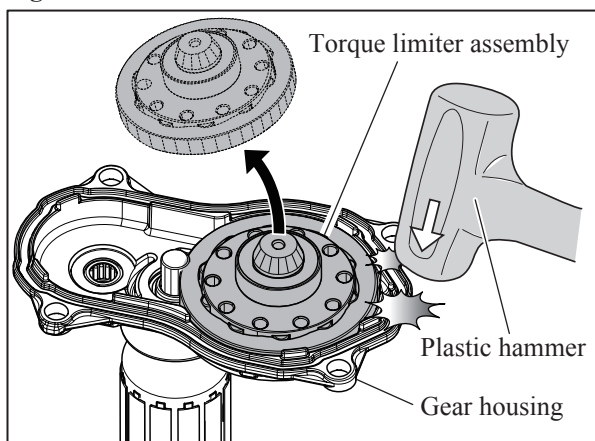

**Fig. 36**

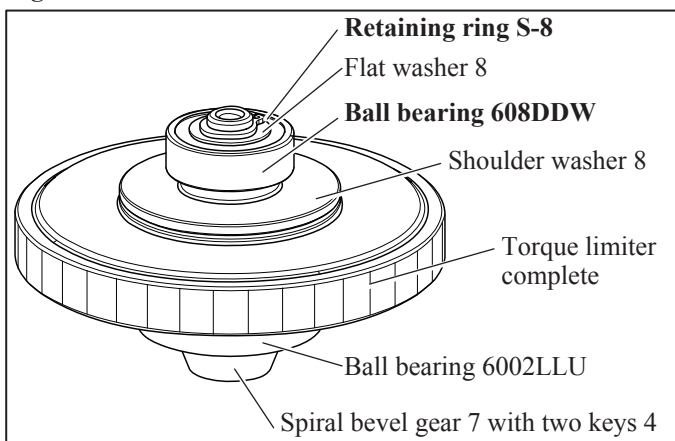

**Fig. 37**

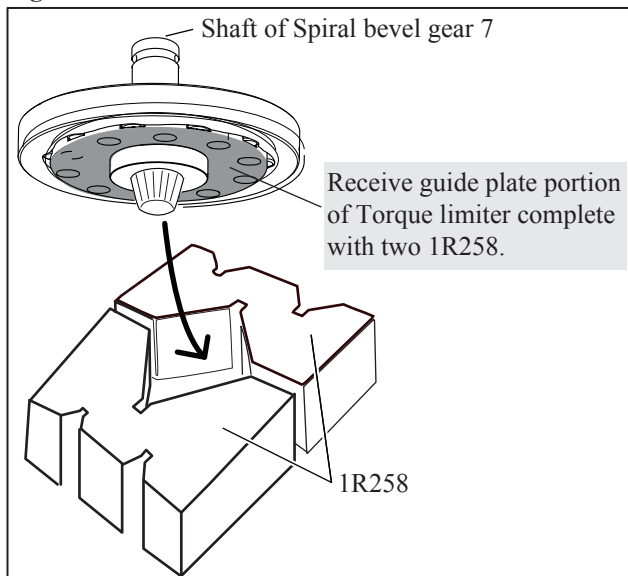

**Fig. 38**

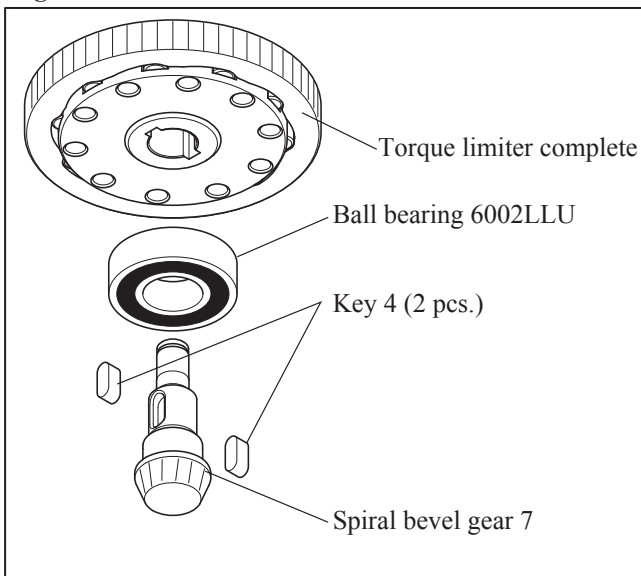

##### ASSEMBLING

Assemble by reversing the disassembly procedure.  
When Shoulder washer 8 is pressfit to Spiral bevel gear 7 in Torque limiter complete, place 1R027 to the round center portion of Shoulder washer 8 to press it down. (**Fig. 39**)

**Fig. 39**

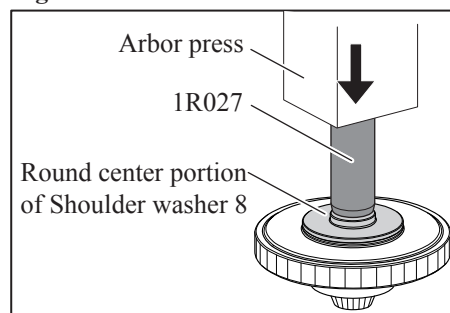

## ► Repair

### [3] DISASSEMBLY/ASSEMBLY

#### [3]-5. Motor

##### DISASSEMBLING

- (1) Do the steps until four 5x25 Tapping screws are removed according to [3]-3-(9) of the previous pages. (Fig. 19)
- (2) Loosen two 4x18 Tapping screws and then remove Rear cover. (Fig. 40)
- (3) While holding Fan by a gloved hand, turn M6 Hex nut counterclockwise using Cordless impact driver with Socket bit 10. (Fig. 41)
- (4) Because Carbon brushes are pressed with Spiral springs to maintain their contacts with Armature's commutator. Slide and detach the spiral springs from Carbon brushes and put them aside. Check that Carbon brushes are detached from Commutator of Armature. (Fig. 42)
- (5) Tap Armature shaft and then pull Crank housing and Gear housing to remove them from Motor housing. (Fig. 43)  
Armature is removed together with Gear housing. (Fig. 44)
- (6) Remove Armature from Gear housing with 1R045. (Fig. 45)

##### ASSEMBLING

Assemble by reversing the disassembly procedure.

Fig. 40

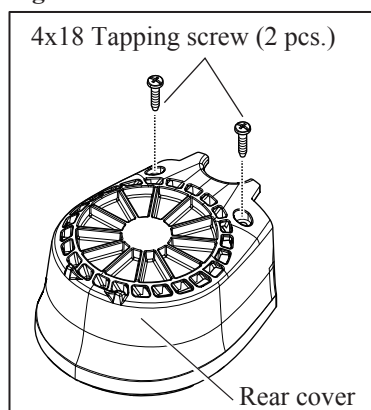

Fig. 41

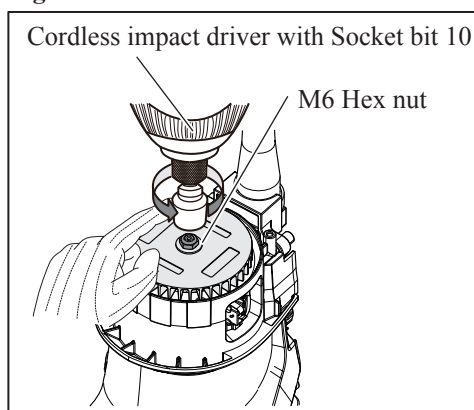

Fig. 42

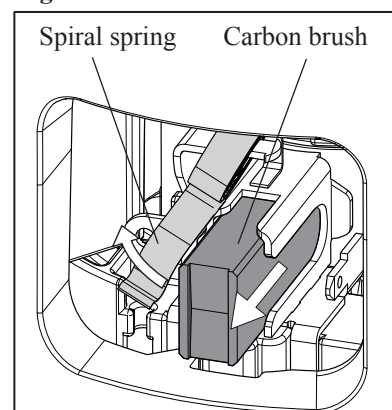

Fig. 43

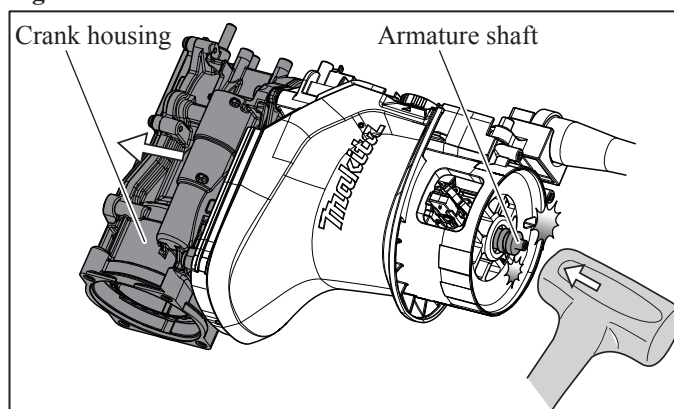

Fig. 44

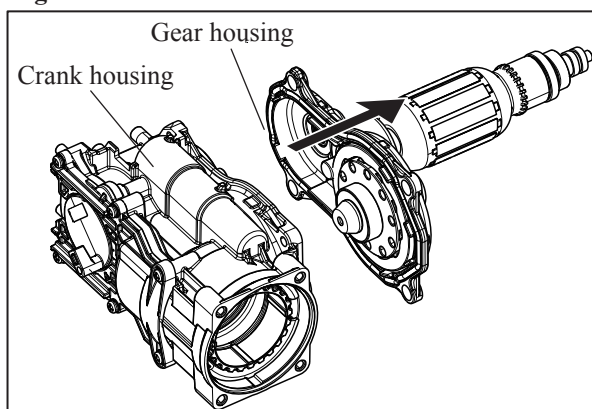
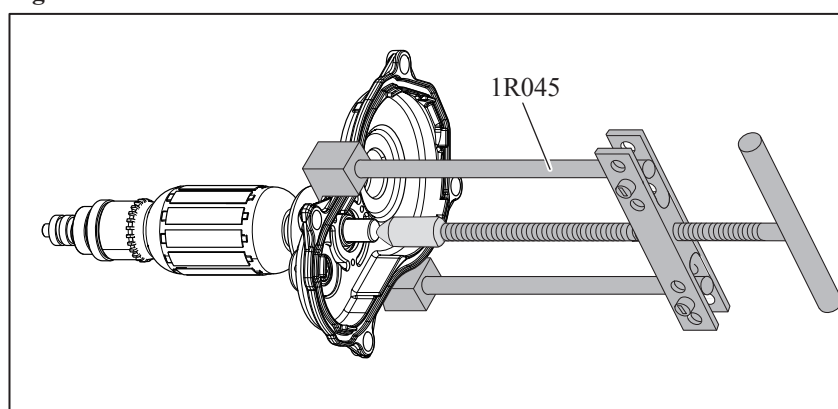

Fig. 45



## ► Repair

### [3] DISASSEMBLY/ASSEMBLY

#### [3]-6. Handle section

##### DISASSEMBLING

Loosen 4x18 Tapping screw and then lever up Handle cover with a slotted screwdriver. (Fig. 46)

Main switch can be replaced. (Fig. 47)

Fig. 46

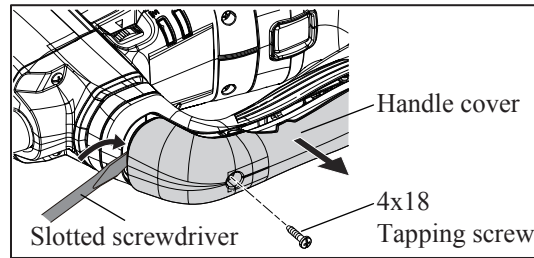
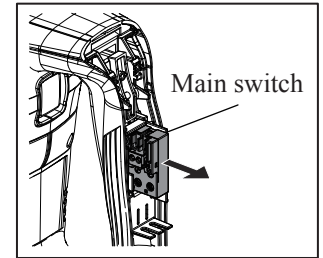

Fig. 47



#### [3]-7. Fastening Torque

Fasten the bolts to the fastening torque listed in Fig. 48.

Fig. 48

Item No.	Description	Q'ty	Fastening torque
⑫	M6x30 Hex socket head bolt	4	7.8 - 12.0 N·m
⑦⑤	M5x25 Tapping screw	1	3.0 - 3.5 N·m
①①④	M6 Hex nut	1	1.8 - 3.7 N·m

#### [4] Maintenance

When replacing Carbon brushes, it is recommended to do replace the following parts (Fig. 49) and apply appropriate amount of lubricants (Figs. 1 to 3) at the same time for longer service life of the machine.

Fig. 49



► **Circuit diagram**

Fig. D-1

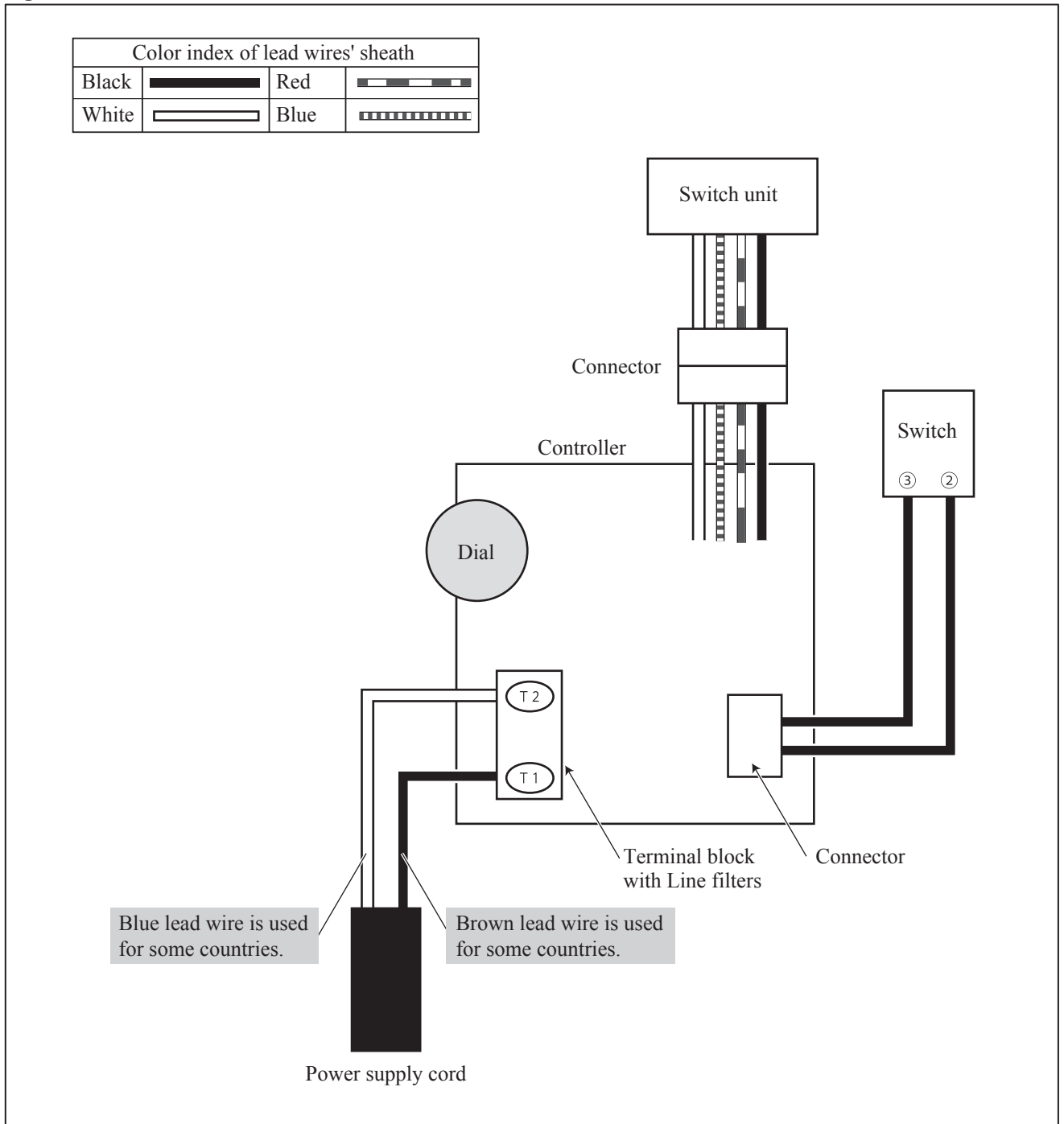

# ▶ Wiring diagram

Fig. D-2

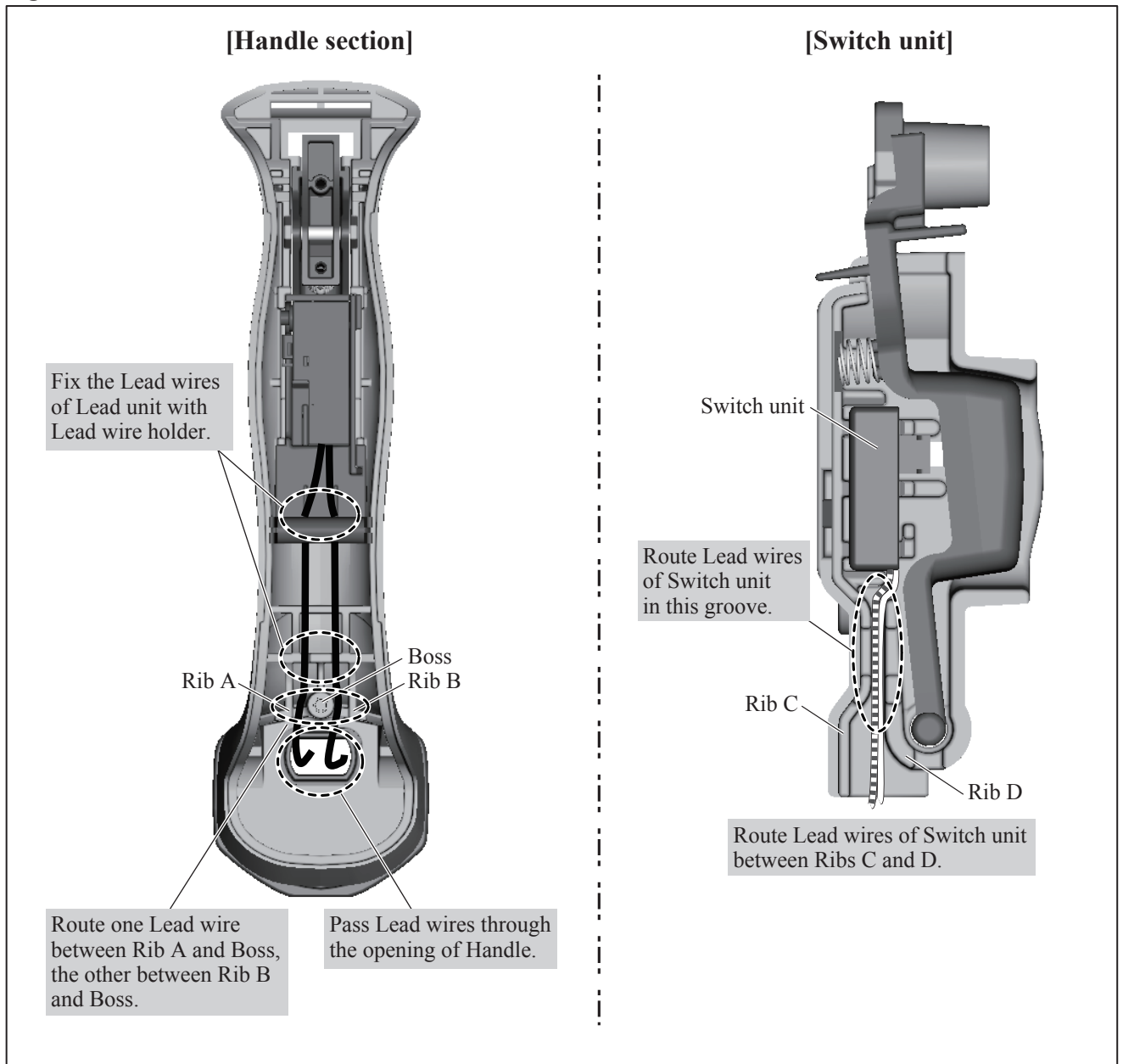

► **Wiring diagram**

Fig. D-3

