

Model DBM230

Wet and Dry Diamond Core Drill 230mm

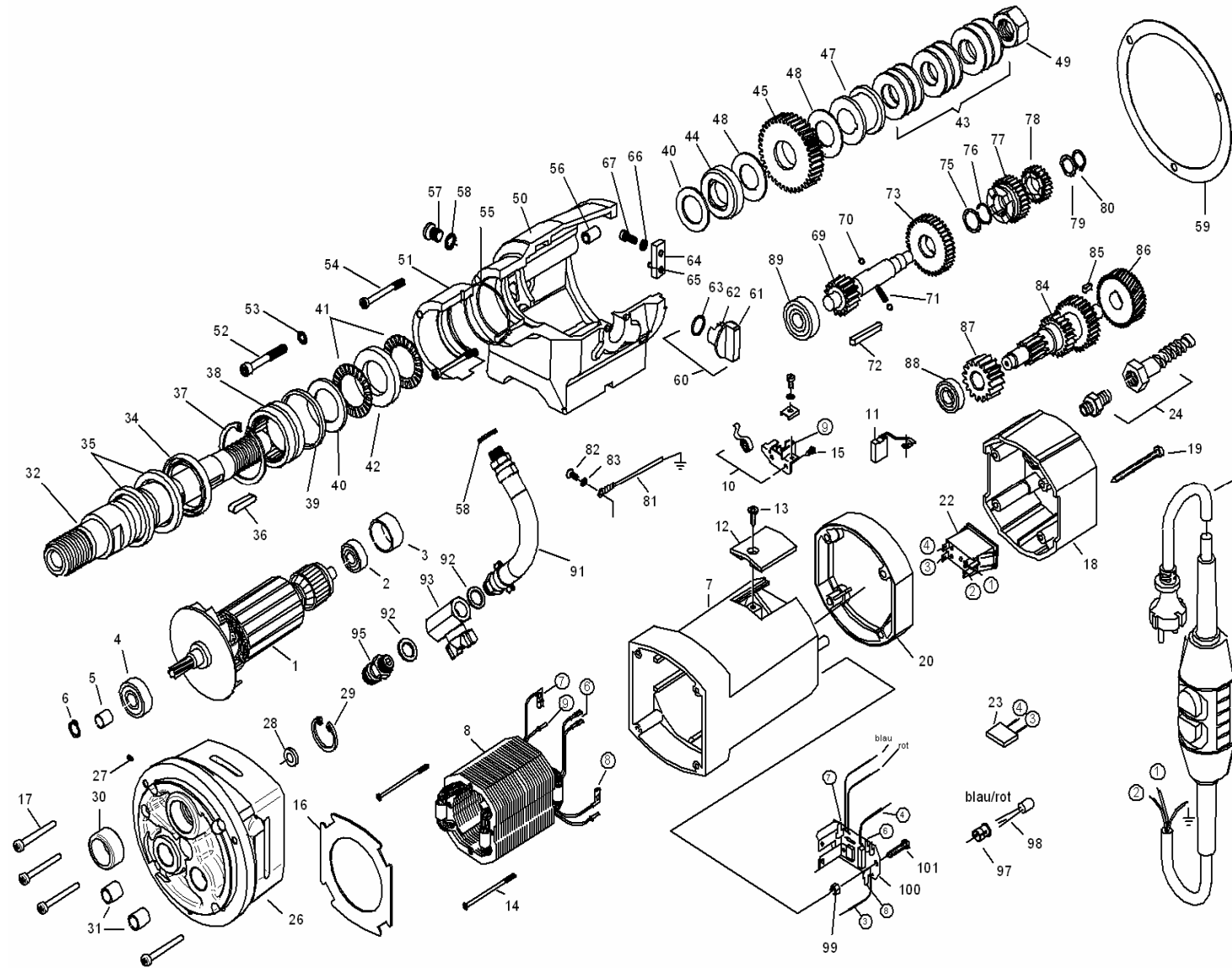

Pos.	Item No.	Description
001	EE73537100	ARMATURE ASS'Y 220-240V
002	EE80410021	BALL BEARING 6000ZZ
003	EE83000031	BEARING BOX
004	EE80410101	BALL BEARING 6201RSZ
005	EE80420160	BEARING BOX 12x15x12,5
006	EE80201321	SAFETY WASHER 12
007	EE80900159	MOTOR HOUSING
008	EE73R53150	FIELD 230-240V ASSY
009		
010	EE80201199	BRUSH HOLDER CPL.
011	EE80700019	BRUSH
012	EE80900073	BRUSH HOLDER CAP
013	EE80201270	PAN HEAD SCREW 4,2x13
014	EE80201234	SCREW MEPLAST 3x78
015	EE80201252	PAN HEAD SCREW 2,9x13
016	EE85000097	BAFFLE PLATE
017	EE80201425	TAPPING SCREW 4,5X60
018	EE73537240	HOUSING A
019	EE80201286	TAPPING SCREW 4,8x70
020	EE75613425	HOUSING B
021		
022	EE80600119	SWITCH
023	EE80500010	CONDENSER
024	EE80600174	CORD GUARD
025	EE73533262	PRCD-SWITCH CPL.
026	EE73537610	GEAR HOUSING COVER
027	EE80200757	GRUB SCREW M6x6
028	EE83000042	SHAFT SEALING RING KEIV 15x21x3
029	EE80201351	RETAINING RING 32/1,5
030	EE80420150	NEEDLE BEARING HK 2012
031	EE80420130	NEEDLE BEARING HK 1212
032	EE73531420	SPINDLE
033		
034	EE83000073	SHAFT SEALING RING 40x52x7
035	EE83000074	SHAFT SEALING RING 40x55x7
036	EE80200607	FITTING KEY 6x6x32
037	EE80201337	SAFETY WASHER 5/2
038	EE80420155	NEADLE BEARING NKS 37
039	EE73531450	RING
040	EE80420165	DISK LS 3047
041	EE80420038	AXIAL-NEEDLEBEARING AXK3047A
042	EE80420168	DISK ZS3151
043	EE80200717	PLATE SPRING 50x25,4x3
044	EE73531425	SUPPORTING DISK
045	EE73533430	GEAR
046		
047	EE73531423	SIZE ZYLINDER
048	EE85000076	BREAK DISK
049	EE80201010	HEX NUT M24x1,5
050	EE73537400	GEAR HOUSING

Model DBM230
Wet and Dry Diamond Core Drill 230mm

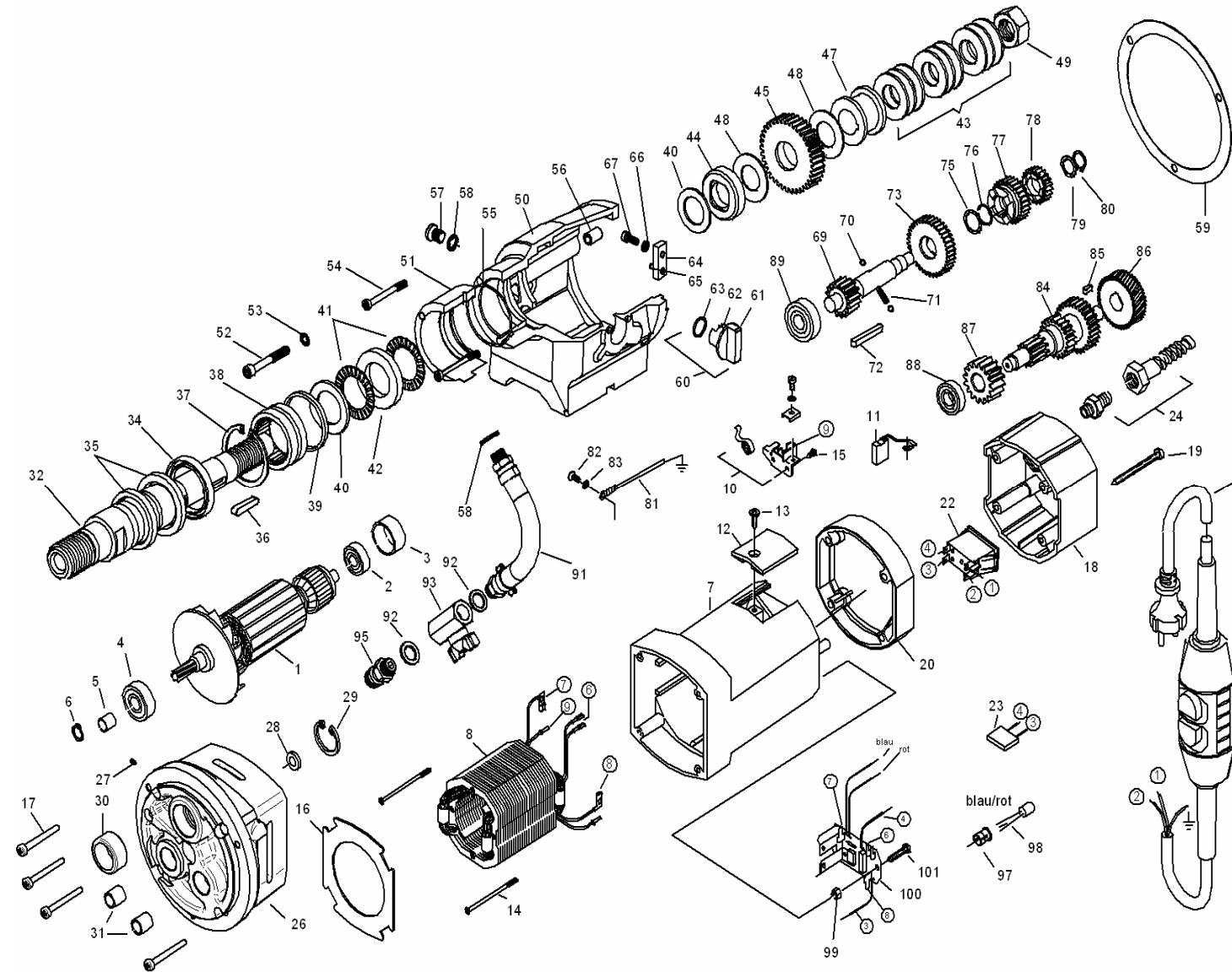

Pos.	Item No.	Description
051	EE73531410	RING
052	EE80201125	HEX. SOCKET HEAD BOLT M6x25
053	EE80201362	STOP RING S6
054	EE80201211	HEX. SOCKET HEAD BOLT M5x55
055	EE83000080	O-RING 50,52x1,78
056	EE80201050	BUSH
057	EE80201406	LOCKING SCREW 1/8"
058	EE83000106	GASKET RING 1/8"
059	EE82000066	GASKET
060	EE73531545	SPEED CHANGE LEVER ASS'Y
061	EE73531540	TOGGLE KNOB
062	EE80200578	PIN 4,6x12
063	EE83000081	O-RING 18,77x1,75
064	EE73531542	GEAR LEVER
065	EE80200579	PIN 5,6x14
066	EE80201364	LOCK WASHER 5
067	EE80201230	HEX. SOCKET HEAD BOLT M5x12
068		
069	EE73533490	GEAR SHAFT
070	EE80410081	STEEL BALL 5
071	EE80200694	COMPRESSION SPRING D079
072	EE80200610	FITTING KEY 6x6x50
073	EE73531460	SPUR GEAR A
074		
075	EE73531494	RING 20x24,5x1
076	EE80200749	RING SPRING 20
077	EE73531550	CONTROL GEAR
078	EE73531470	SPUR GEAR B
079	EE80200514	RING 16x22x1
080	EE80201316	SAFETY WASHER 16x1
081	EE73325185	GROUND WIRE KABLE
082	EE80201200	OVAL HEAD SCREW M4x6
083	EE80200752	SELF LOCK 4,3
084	EE73531500	LAYSHAFT
085	EE80200600	FITTING KEY 5x5x10
086	EE73531440	SPUR GEAR C
087	EE73533510	SPUR GEAR D
088	EE80410031	BALL BEARING
089	EE80410160	BALL BEARING 6302
090		
091	EE83000109	TUBE
092	EE83000107	GASKET RING 1/4"
093	EE83000117	BALL VALVE
094		
095	EE83000124	SUPPORT
097	EE80601153	HOLDER
098	EE80601154	LED
099	EE80201295	PLASTIC NUT
100	EE80601155	CIRCUIT BOARD
101	EE80201273	PAN HEAD SCREW 4,2x25

Bohrständer BST 230 M

Artikel Nr.: 0963M

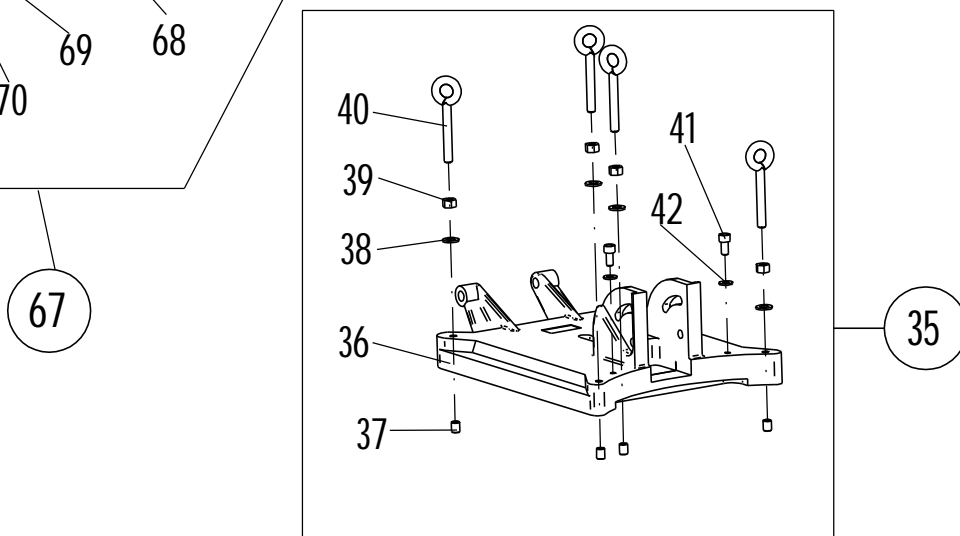
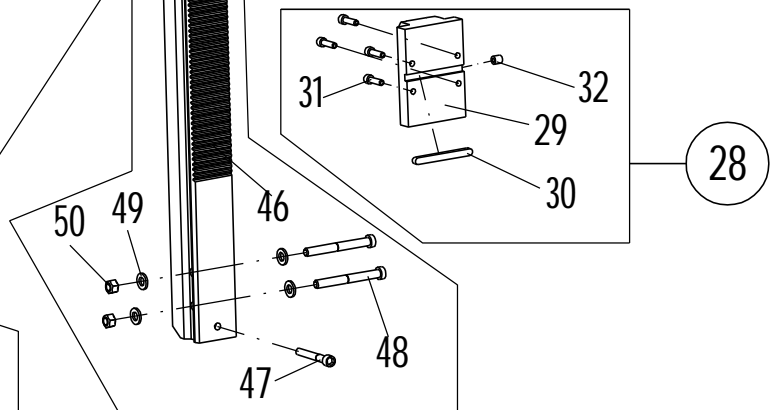
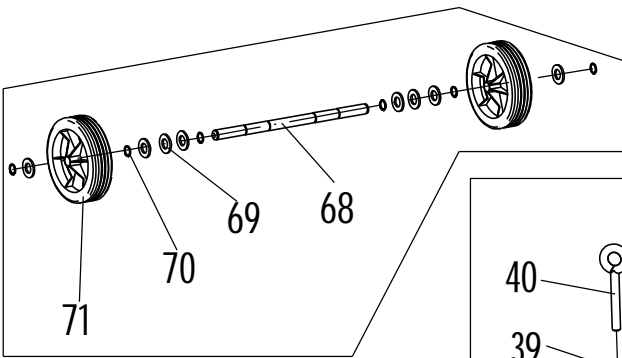
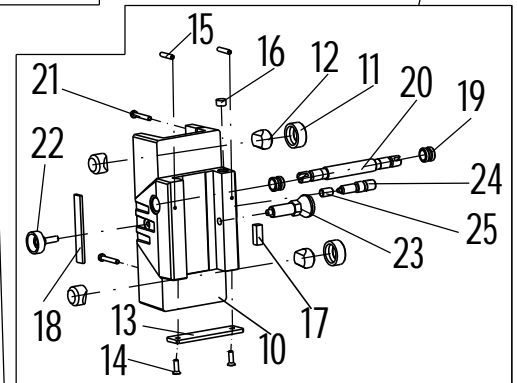
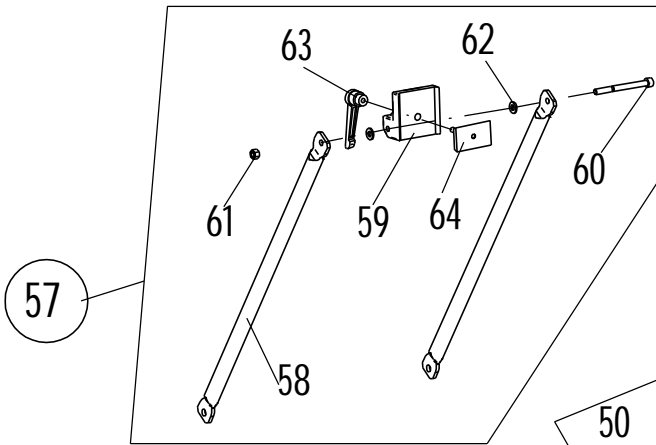
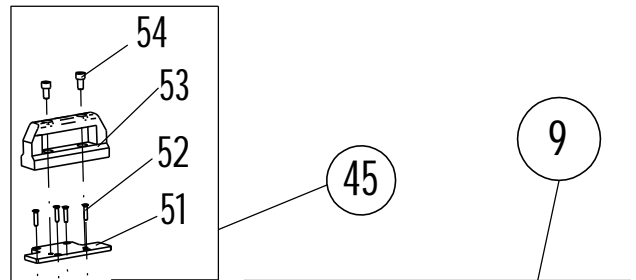
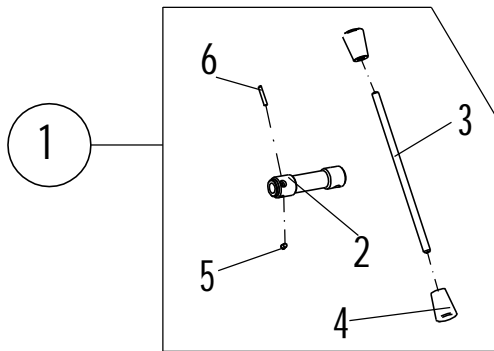



Vakuump Technik GmbH
EIBENSTOCK

Bohrständer BST 230 M
Ersatzteilpreise
Artikel Nr.: 0963M
MAKITA

Datum: 14.04.2005

Stand: 23.01.2007

Seiten : 2

Seite : 1

Lfd. Nr.	Bezeichnung	Stück	Bestell.-Nr.	Ersatzteilpreis €/Stück
1	Drehkreuz kompl. (incl. 2-6)	1	EE15200100	
2	Drehkreuz	1	EE796UN740	
3	Hebel	1	EE796UN746	
4	Kegelknopf	2	EE85000193	
5	Federndes Druckstück	1	EE85000157	
6	Zylinderstift Ø 5x30 DIN 6325	1	EE80200627	
9	Schlitten kompl. (incl. 10-25)	1	EE79600780	
10	Schlitten	1	EE796UN780	
11	Klemmschraube	2	EE796UN765	
12	Druckstück	4	EE796UN763	
13	Halteblech	1	EE796UN915	
14	Senkschraube M6x20 DIN 965 ZN	2	EE80201158	
15	Gewindestift M6x30 DIN 914 ZN	2	EE80200774	
16	Dosenlibelle Ø 14	1	EE85000153	
17	Horizontallibelle H29	1	EE85000152	
18	Flachklemmstück , groß	1	EE796UN778	
19	Stahlbuchse	2	EE796UN770	
20	Ritzelwelle , groß	1	EE7300W730	
21	Zylinderschraube M6x40 DIN 912 ZN	2	EE80201186	
22	Rändelschraube M8x32	1	EE85000189	
23	Arretierbolzen mit M16	1	EE85000191	
24	Feststeller	1	EE796UN735	
25	Helicoil-Gewindeeinsatz M12x18	1	EE85000177	
28	Adapterplatte kompl. (incl. 29-32)	1	EE79600911	
29	Adapterplatte 145	1	EE796UN911	
30	Paßfeder DIN 6885 A 10x8x100	1	EE80200613	
31	Zylinderschraube M8x20 DIN 912 ZN	4	EE80201147	
32	Bohrbuchse Ø B 6x10 DIN 179 A	1	EE80201051	
35	Fuß kompl. (incl. 36-42)	1	EE79600895	
36	Fuß	1	EE796UN895	
37	Helicoil- Gewindeeinsatz M12x24	4	EE85000163	
38	U-Scheibe Ø 13 DIN 125 ZN	4	EE80201381	
39	Sechskantmutter M12 DIN 934 ZN	4	EE80201014	
40	Ringschraube M12x85	4	EE80201144	
41	Zylinderschraube M10x20 DIN 912 ZN	2	EE80201146	
42	U-Scheibe Ø 10,5 DIN 125 ZN	2	EE80201380	
45	Säule kompl. (incl. 46-54)	1	EE79600950	
46	Säule mit Skalen	1	EE796UN950	
47	Zylinderschraube M10x75 DIN 912 ZN	1	EE80201139	



Vakuump Technik GmbH
EIBENSTOCK

Bohrständer BST 230 M

Ersatzteilpreise
Artikel Nr.: 0963M
MAKITA

Datum: 14.12.2005

Stand: 23.01.2007

Seiten : 2

Seite : 2

Lfd. Nr.	Bezeichnung	Stück	Bestell.-Nr.	Ersatzteilpreis €/Stück
49	U-Scheibe Ø 13 DIN 9021 Plast	4	EE80201388	
50	Sechskantmutter M12 DIN 985	2	EE80201036	
51	Griffplatte	1	EE796UN919	
52	Gewinde-Schneideschr. M5x20 DIN 7516	4	EE80201168	
53	Oberer Haltegriff	1	EE796UN824	
54	Zylinderschraube M8x16 DIN 912 ZN	2	EE80201160	
57	Abstützungsset kompl. (incl. 58-64)	1	EE79600853	
58	Abstützungsrohr	2	EE796UN853	
59	Abstützungshalter	1	EE796UN918	
60	Zylinderschraube M8x90 DIN 912 ZN	1	EE80201255	
61	Sechskantmutter M 8 DIN 985	1	EE80201221	
62	U-Scheibe Ø 8,4 DIN 9021 Plast	2	EE80201383	
63	Klemmhebel M10-1 Innengew.	1	EE85000188	
64	Platte mit Gewindespindel M10	1	EE796UN930	
67	Radachse kompl. (incl. 68-71)	1	EE79600809	
68	Radachse	1	EE796UN809	
69	Sicherungsring D 14x1 DIN 471	6	EE80201318	
70	U-Scheibe Ø 15 DIN 125 ZN	8	EE80201352	
71	Vollgummirad	2	EE85000178	
	Zubehör:			
	Sechskant-Stiftschlüssel SW 6	1	EE80430043	
	Sechskant-Stiftschlüssel SW 8	1	EE80430044	
	Vakuump-Set komplett	1	35856	